

HIGHLEAD

GG20618-4

**Compound-feed, Four needles, Heavy Material
Lockstch Sewing Machine**

**Instruction Manual
Parts Catalog**

CONTENTS

PRECAUTIONS BEFORE STARTING OPERATION	1
PREPARATION FOR OPERATION	
1. Power cable connection	2
2. Connection of control box	3
3. Adjustment of needle bar stop position	3
CAUTIONS ON USE	
1. Oiling (1)	4
2. Oiling (2)	4
3. Oiling condition	4
4. Cautions on operation	4
OPERATION	
1. Installation of needles	5
2. Winding of bobbin thread	5
3. Selection of thread	5
4. Threading of needle threads	6
5. Adjustment of feed (stitch) length and stitch reversing (touch-back)	6
6. Setting of bobbin	7
7. Threading of bobbin threads	7
8. Tension adjustment of bobbin threads	8
9. Balance of thread tension	8
10. Needle thread tension	8
11. Adjustment of presser foot pressure	8
12. Timing between rotating hook motion and needle motion	8
13. Adjustment of feed dog height	9
14. Relationship between rotating hook motion and take-up lever motion	10
15. Relationship between hook motion and opener motion	10
16. Relationship between needle motion and feed dog motion	10
17. Safety clutch device	11
18. Upper feed adjustment (needle side)	12
19. Outside presser foot and inside presser vertical stroke adjustment	13
20. Adjustment of forward/backward stitch length	13
SPECIFICATIONS	14

PARTS CATALOG

1. Arm bed its accessories -----	1
2. Arm shaft mechanism -----	3
3. Upper shaft & presser foot mechanism -----	5
4. Needle bar & thread take-up lever mechanism -----	7
5. Stitch regulator mechanism -----	9
6. Lower shaft & feed rock shaft mechanism -----	11
7. Hook saddle mechanism -----	13
8. Accessories -----	15

PRECAUTIONS BEFORE STARTING OPERATION

1. Safety precautions

- 1) When turning the power on, keep your hands and fingers away from the area around/under the needle and the area around the pulley.
- 2) Power must be turned off when the machine is not used, or when the operator leaves his/her seat.
- 3) The power must be turned off before tilting the machine head, installing or removing the "V" belt, adjusting the machine, or when replacing.
- 4) Avoid placing fingers, hairs, bars etc. near the pulley, "V" belt, bobbin winder pulley, or motor when the machine is operation. Injury could result.
- 5) Do not insert fingers into the thread take-up cover, under/round the needle, or pulley when the machine is in operation.
- 6) If a belt cover, finger guard, and/or eye guard are installed, do not operate the machine without these safety devices.

2. Precaution before Starting Operation

- 1) If the machine's oil pan has an oil sump, never operate the machine before filling it.
- 2) If the machine is lubricated by a drop oiler, never operate the machine before lubricating.
- 3) When a new sewing machine is first turned on, verify the rotational direction of the pulley with the power on. (the pulley should rotate counterclockwise when viewed from the pulley.)
- 4) Verify the voltage and (single or three) phase with those given on the motor nameplate.

3. Precaution for Operating Conditions

- 1) Avoid using the machine at abnormally high temperature (35°C or higher) or low temperature (5 °C or lower). Otherwise, machine failure may result.
- 2) Avoid using the machine in dusty conditions.
- 3) Avoid using the machine in areas where too much electrical noise, resulted from the high-frequency welder and others, is generated.

PREPARATION FOR OPERATION

1. Power cable connection

1) Connection to Power Supply

When connecting the power supply connector to the control box, the connector should be completely plugged in the proper receptacle after confirming the connector type and matching direction.

- A. In case of three-phase electrical power system, the “U” phase should be connected to the red lead, the “V” phase to the white lead, and the “W” phase to the black lead. The motor rotary direction depends, however, upon the setting of the internal switch in the control box as described in Paragraph 1-(3)

CAUTION: The green wire must be connected to the ground terminal in order to ground the motor properly.

- B. The appropriate power fuse capacity is as follows.
- | | | |
|--------------|------------|-----|
| Power supply | 200V-240V: | 10A |
| | 100V-120V: | 15A |

2) Lamp Leads

- A. When installing the illuminating lamp(6V,15-20W),The connecting wire is attached on the back of the Control box. It should be removed and connected by removing the insulating tube from the wire and stripping properly. The wire connections should be, then, insulated by wrapping insulating tape on the wires.

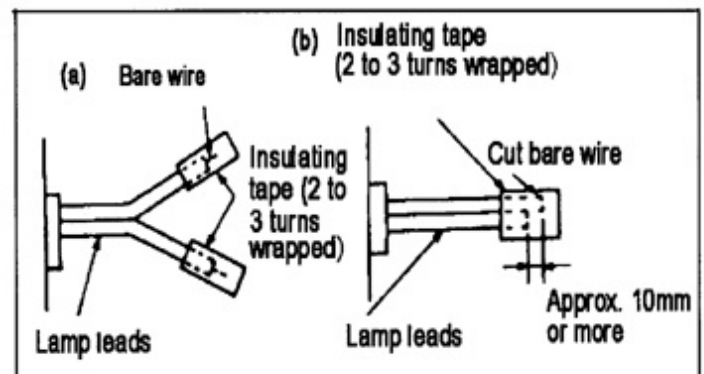

CAUTION: The power switch must be Turned off before connecting the lamp.

- B. When the illuminating lamp is not used, the end of the lamp leads must be insulated as (a) or (b) as shown in the figure on right side. If a short circuit occurs failing to insulate, the transformer in the control box will be possibly burned out.

3) Rotary direction

It is possible to change the rotary direction of the motor by removing the rubber cap from the bottom left side of the front cover on the control box, and push the internal direction selector switch. The built-in lamp in the internal switch is off when the motor is rotating counterclockwise as facing to the motor pulley, and on when rotating clockwise. The rotary direction has been set to counterclockwise as facing to the motor pulley, matching with the machine prior to shipping

2. Connection of control box

The control box should be connected as shown to the right.

Note: (1) Be sure to turn the power switch off for safety before connecting or disconnecting the connectors.

(2) The combination of the machine heads with the motor control panels are specified below.

Use special care for the correct

combination when replacing the machine head or motor control panel.

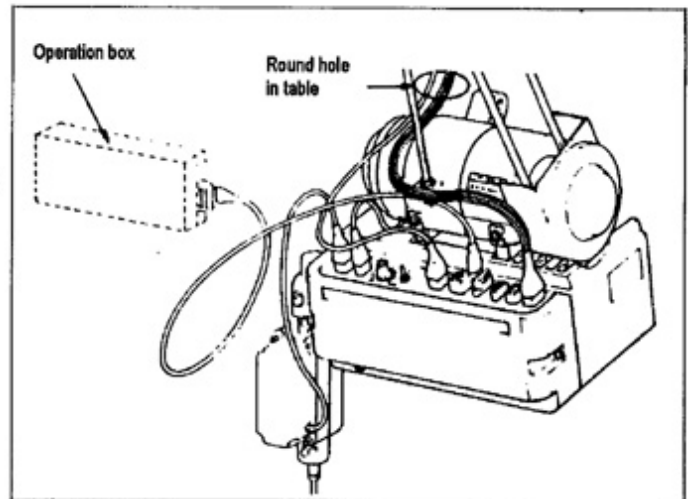

3. Adjustment of needle bar stop position

1) Adjust of "UP" position

When the pedal is kicked down by heel, the machine stops at "UP" position. If the marks deviate larger than 3 mm, adjust as follows.

- Disconnect the plug (12 pins) of cable from the machine head.
- Run the machine and stop at "UP" position.
- While holding the pulley, insert the "adjusting tool" in the hole "A", then remove the tool.

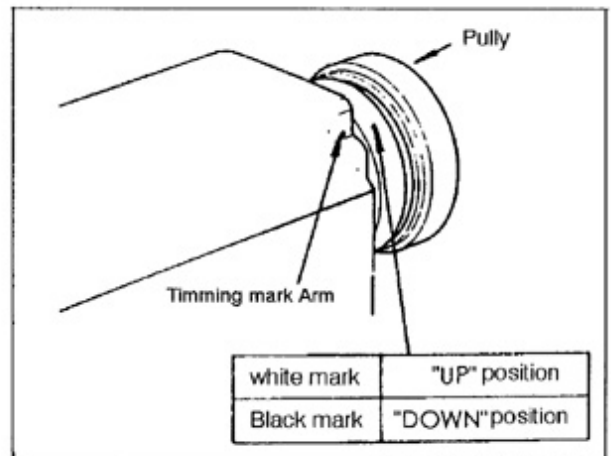

2) Adjust of "Down" position

When the pedal is "Neutral" the machine stops at "Down" position. If the marks deviate large than 5 mm, adjust as follows.

- Disconnect the plug (12 pins) of cable from the machine head
 - Run the machine and stop at "Down" position.
 - While holding the pulley, insert the "adjusting tool" in the hole "B", then remove the tool.
- 3) Confirm the stop operation, then set the plug (12 pings) coming from the machine head into the receptacle.

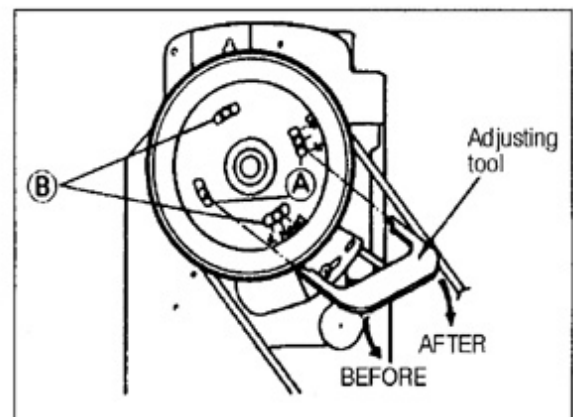

CAUTIONS ON USE

1. Oiling (1)

Filling the oil to the fount.

Oil level should be periodically checked. If oil level is little, Please replenish oil to enough

For oil, Use white spindle oil.

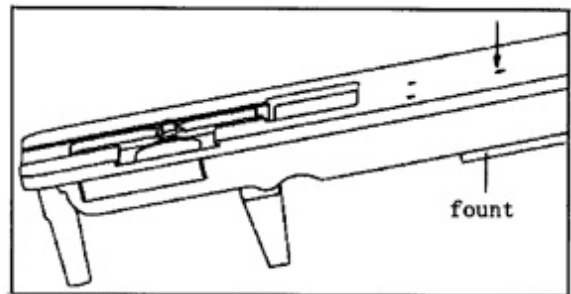

2. Oiling (2)

When a new sewing machine is used for the first time, or sewing machine left out of use for considerably long time is used again, replenish a suitable amount of oil to the portions indicated by arrow in the below figure

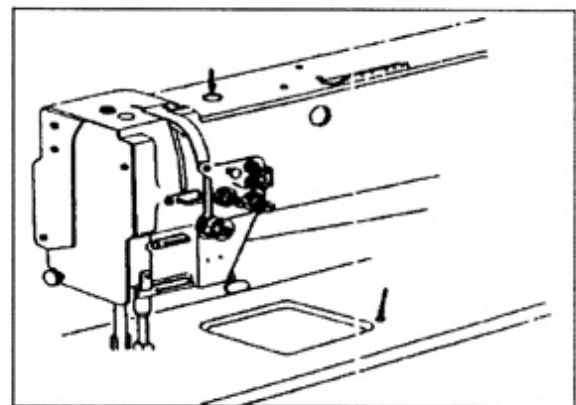
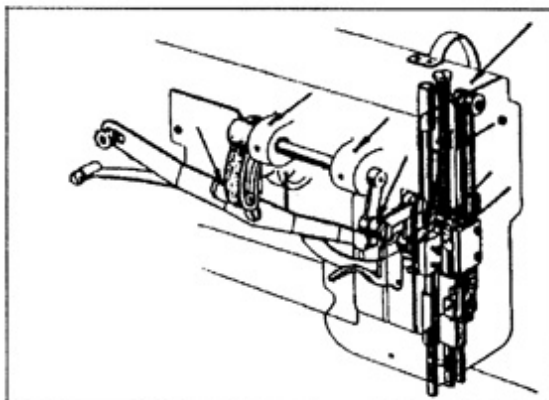

3. Oiling condition

See dripping of oil through the oil sight hole to check oiling condition during operation.

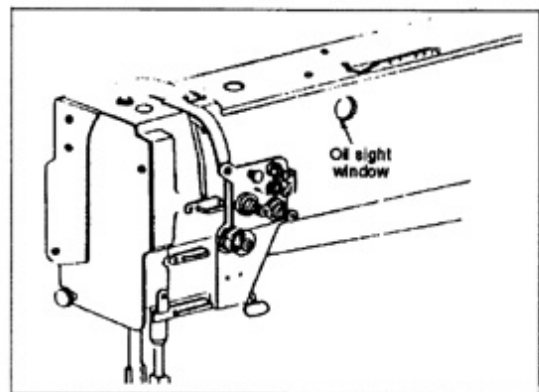

4. Cautions on operation

- When the power is turned on or off, keep foot away from the pedal.
- It should be noted that the brake may not work when the power is interrupted or power failure occurs during sewing machine operation.
- Since dust in the control box might cause malfunction or control troubles, be sure to keep the control box cover close during operation.
- Do not apply a multimeter to the control circuit for checking; otherwise voltage of multimeter might damage semiconductor components in the circuit.

OPERATION

1. Installation of needles

Note: Before installing the needles, be sure to turn off the power.

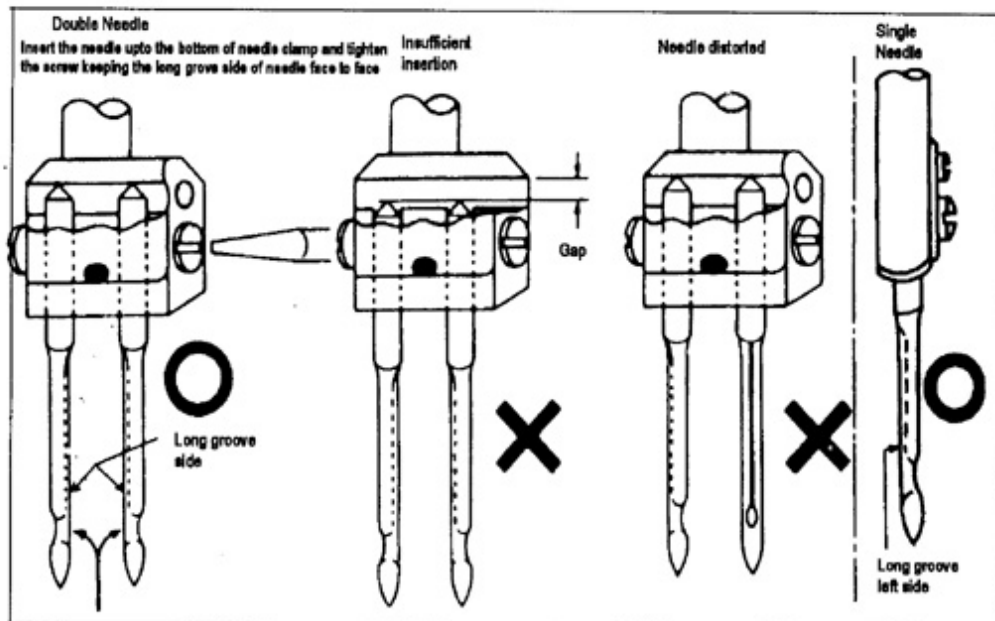

2. Winding of bobbin thread

Note: When bobbin thread is wound, keep the presser foot lifted.

Adjustment:

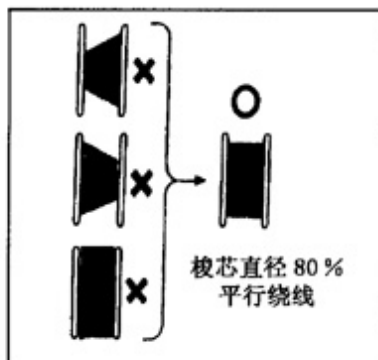

3. Selection of thread

It is recommended to use "S" twist thread in the left needle (viewed from front), and "Z" twist thread in the right needle. When discriminate use of needle threads is impossible, use "Z" twist thread in both the needles.

For bobbin thread, "S" twist thread as well as "Z" twist thread can be used.

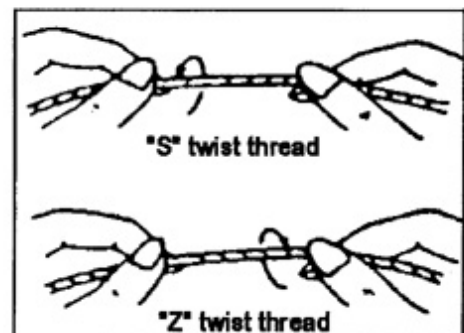

4. Threading of needle threads

- a) Pass each needle thread through thread guide A

Note: When thin slippery thread (polyester Thread or filament thread, for example) is used pass the thread through thread guide B as well.

- b) With the take-up lever located at the upper most position, pass each needle thread in the order shown in the following figure.

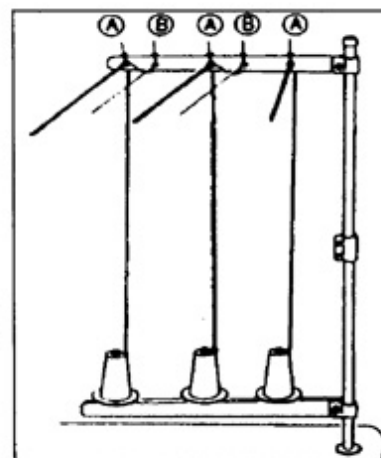

Note: Pressing the upper thread loosening button shown in the figure below

opens the saucer of the upper thread tension adjuster, and the upper thread can easily pulled out.

5. Adjustment of feed (stitch) length and stitch reversing (touch back)

Note: To make feed (stitch) length smaller, depress the feed reverse lever and set the feed length setting dial to a desired position

Touch-back button . . . Direction of stitching can be reversed by depressing this button.

Stitching goes on in reversed direction while the button is held down, and returns to forward direction when the button is released.

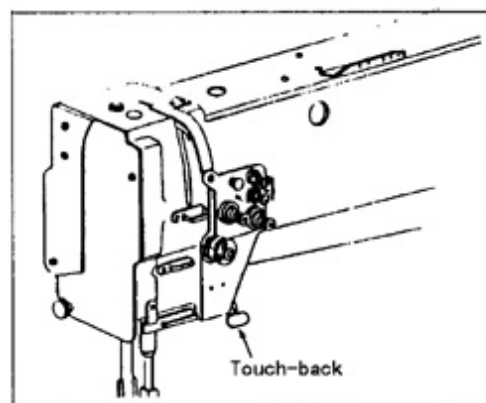
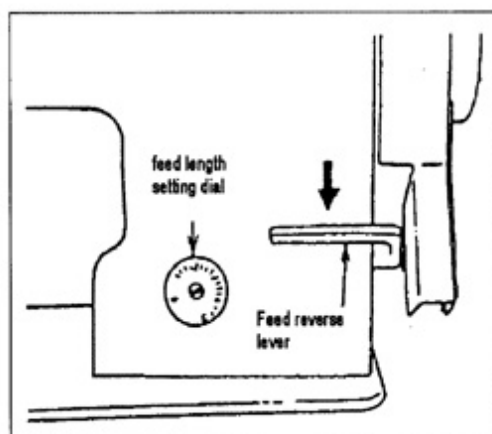

6. Setting of bobbin

- a) Pulling out 5.cm thread tail from the bobbin.
- b) Hold the bobbin so that the bobbin thread is would in right direction and put it into the hook.

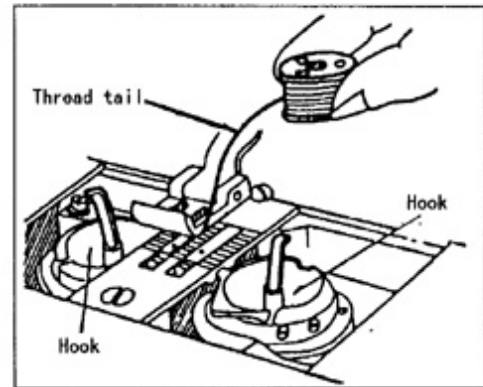

7. Threading of bobbin threads

- a) Put the hook into the bobbin case and press down the latch ①. The thread end should be left on the bed . .

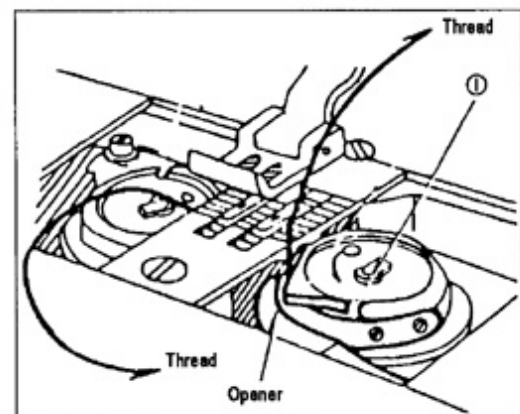

- b) While holding the two needle threads by left hand, rotate the hand-wheel one turn by right hand. By pulling up the needle threads, as shown in the figure, the bobbin threads will be lifted. Each combination of bobbin thread and needle thread should be aligned and led backward.

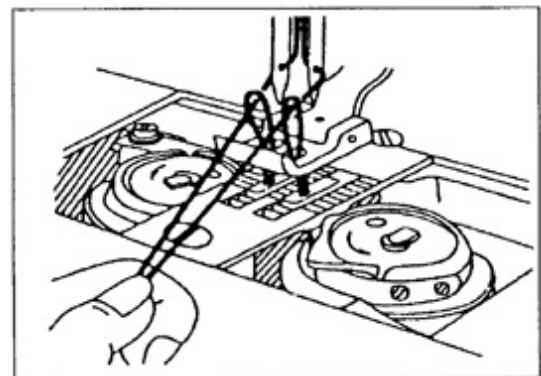

8. Tension adjustment of bobbin threads

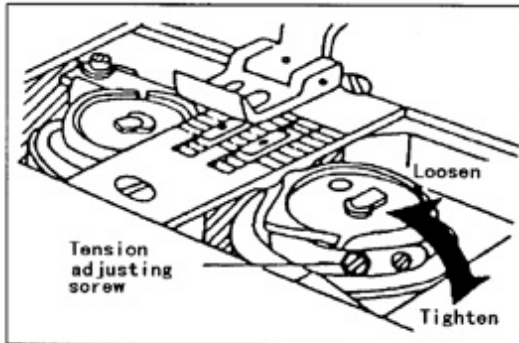

9. Balance of thread tension

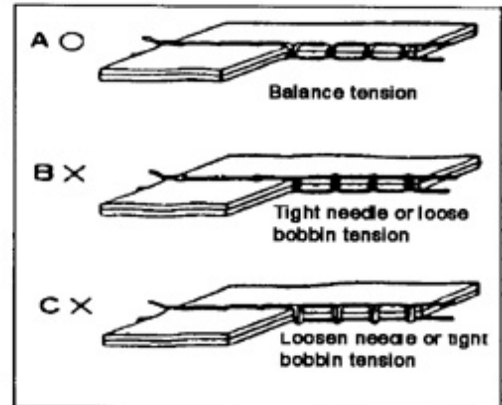

10. Needle thread tension

- Needle thread tension should be adjusted in reference to bobbin thread tension.
- To adjust needle thread tension, turn each tension adjusting nut.
- Needle thread tension can be also adjusted for special fabric and thread by changing intensity and movable range of slack thread adjusting spring.

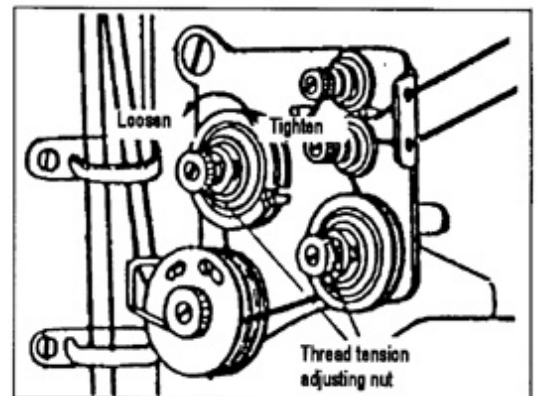

11. Adjustment of presser foot pressure

Pressure to fabric(s) can be adjusted by turning the pressure adjusting screw.

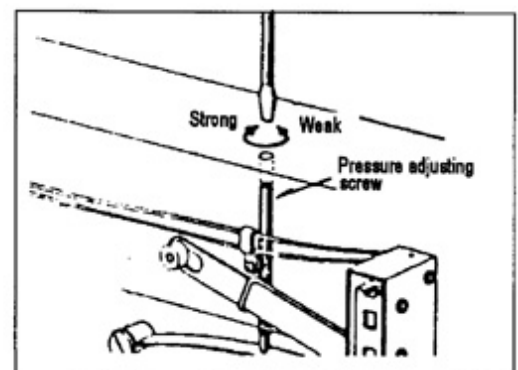

12. Timing between rotating hook motion and needle motion

- (1) Set feed length (stitch length) to "6" on the feed setting dial.
- (2) When needle is lifted 2.4mm from the lower dead point, as shown in Figure, the following positional relationship should be maintained.
 - The upper edge of needle eye should be 2.3mm below the hook point.
 - The hook point should be located at the center of needle axis.
 - Gap between the hook point and the side face of needle should be 0.05mm.

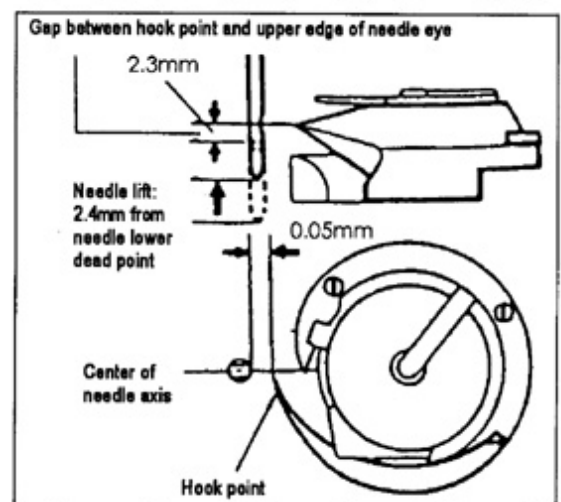

■ Positioning of hook point

- (1) When the needle is at DOWN position, the smaller Crossed helical gears on the right side and left side should be engaged with the large wheel so that the "S" screw of the former gear comes on the front side, and that of the latter gear on the reverse side.
 - (2) Tighten each "S" screw, where is punched for set screw, on the hook shaft.
 - (3) Approximate position of hook "C" screw of hook should be found close to the needle when the needle is at DOWN position.
- ♦ To finely adjust timing between the needle motion and hook motion, loosen the set screw of larger gear wheel and move the gear wheel in its axial direction within a range from 1mm to 2mm.

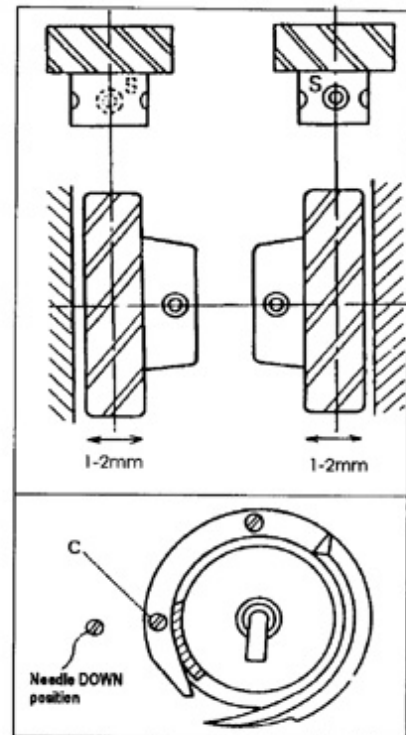

13. Adjustment of feed dog height

Height of feed dog and pressure of presser foot should be adjusted for individual fabric(s) with the following cautions:

- Fabric will be damaged if the feed dog extends too high, or pressure of presser foot is too large.
- Even stitch length cannot be assured if the feed dog is too low or pressure of presser foot is too small.
- Feed dog height should be measured at the point where the needle is at the top position.

For light fabrics Approx. 0.8mm from throat plate

For usual fabrics Approx. 1.0mm from throat plate

For heavy fabrics Approx. 1.2mm from throat plate

Adjustment procedure

- a) Lean the machine head backward.
- b) Turn the hand wheel by hand and stop when the feed dog rises to the maximum height.
- c) Loosen the feed bar set screw.
- d) Vertically move the feed bar (in the direction indicated by arrow in the figure) to adjust it to adequate height.
- e) After the adjustment, tighten the feed bar set screw.

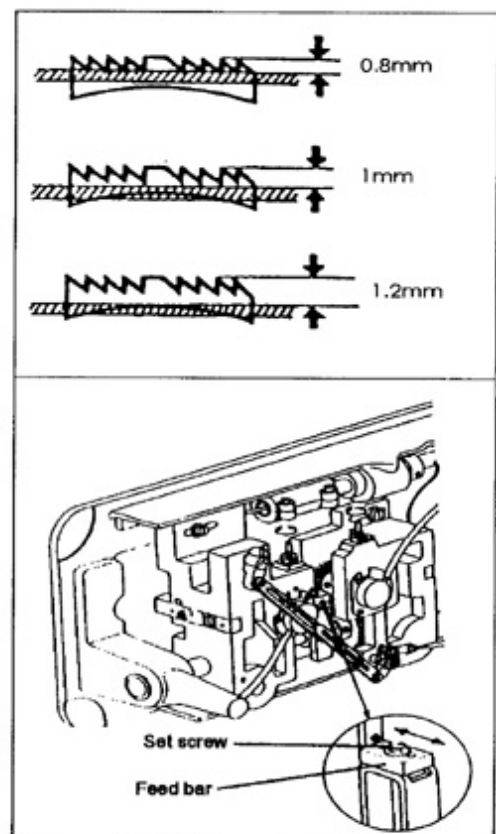

14. Relationship between rotating hook motion and take-up lever motion

When the timing belt (toothed belt) was removed for its replacement, for example, the relationship between rotating hook motion and take-up lever motion should be adjusted as follows:

- Turn the balance wheel and stop when the take-up lever is lifted to its upper dead point.
- Lean the machine head backward and make sure the arrow (timing mark) put on the timing belt is in line with the black line on the boss of lower shaft bearing.
- If the timing mark is not in line with the black line, remove the timing belt and install it again to adjust.

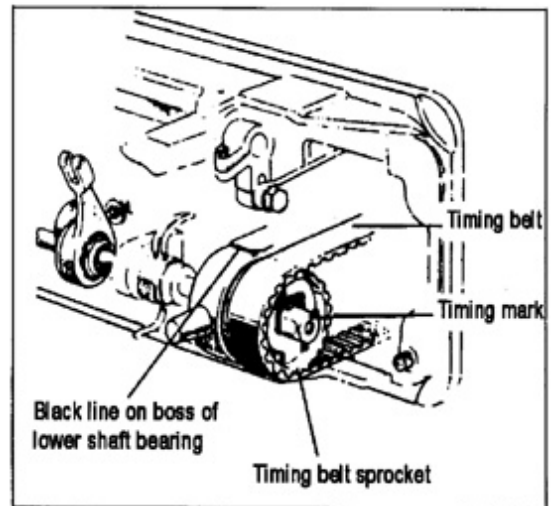

15. Relationship between hook motion and opener motion

- Turn the balance wheel by hand and stop when the opener holder is located most remotely from the throat plate.
- Make sure gap between the bobbin case holder A and the opener is approximately 0.2mm.
- If the gap is too large or small, loosen the opener holder set screw B and adjust position of the opener.

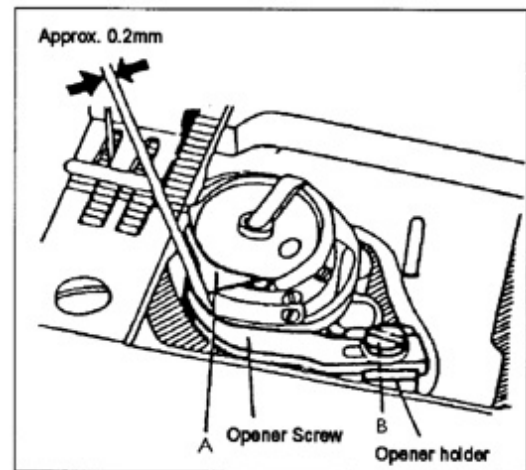

16. Relationship between needle motion and feed dog motion

- Set feed length to "0" on the feed setting dial.
- Lean the machine head backward.
- Loosen the feed lifting rock shaft crank set screws A and B.
- Set the needle at the lowest position.
- Adjust the distance between presser rod and vibration prevention rod to 9mm and temporarily tighten the feed lifting rock shaft crank set screws A and B.
- Check that the right feed lifting rock shaft crank is connected with the link at right angle, as shown in Figure.

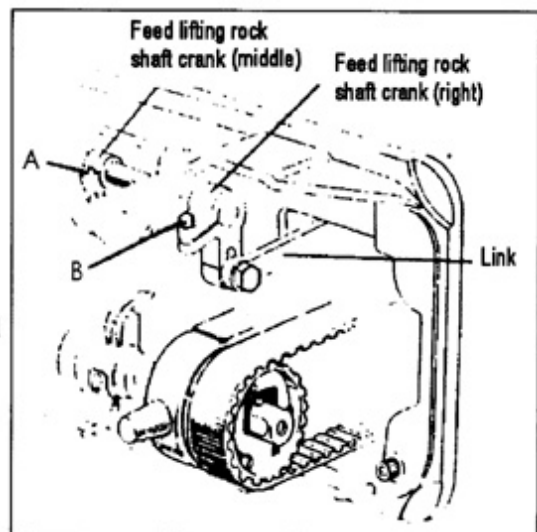

- g) If the connection is not at right angle, remove the back cover, loosen screw C and move the right link to connect the right feed lifting rock shaft with the link at right angle.
- h) After the completion of adjustment, fully tighten the screws A , B and C.
- At this time make certain that needle can enter the feed dog needle hole at the center of the hole.

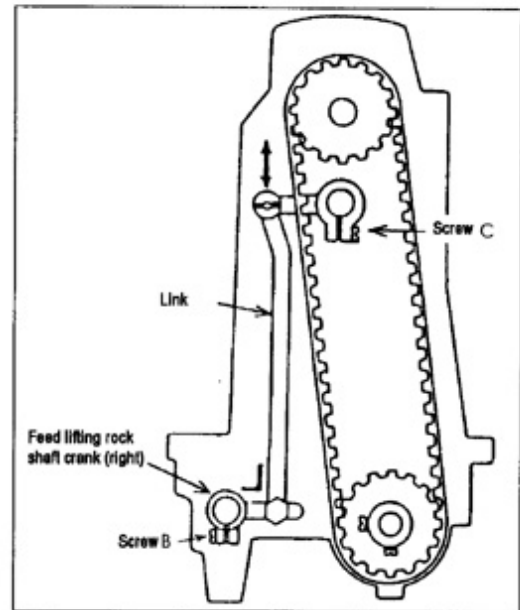
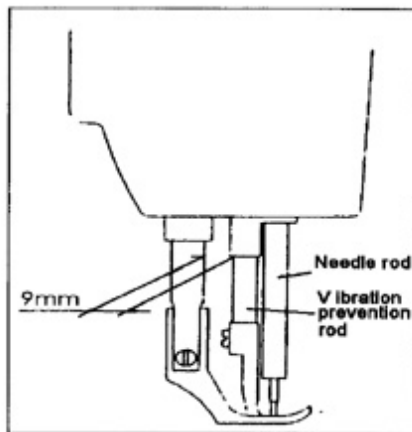

17. Safety clutch device:

Safety clutch device is installed to prevent the hook and cog belt from damage in case the thread is caught into the hook when the machine is loaded abnormally during operation.

(1) Function of safety clutch.

- a) When the safety clutch acts, the cog belt pulley will be unloaded. then the rotation of hook shaft will stop. The arm shaft only will rotate. Stop the operation of machine.
- b) Clean the thread thoroughly which is caught into the hook.
- c) Turn the cog belt hub by hand, and check whether the hook Shaft rotates lightly and properly, place the clutch device as follows.

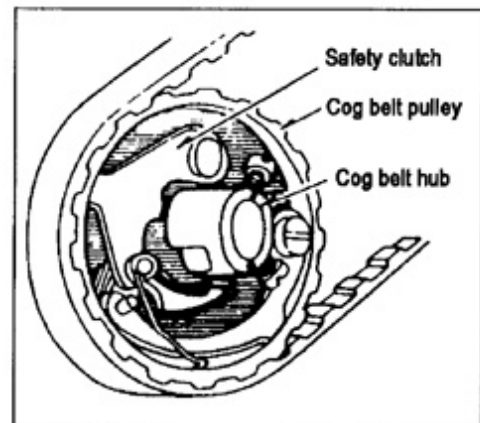

(2) How to set the safety clutch.

- a) While pressing down the push button on the opposite side of bed by left hand, turn the balance wheel slowly by right hand away from you as shown in the figure.
- b) The balance wheel will stop by the gear plate, but turn the balance wheel more firmly.
- c) Release the push button.
- d) As shown in the Figure, the safety clutch device is set.

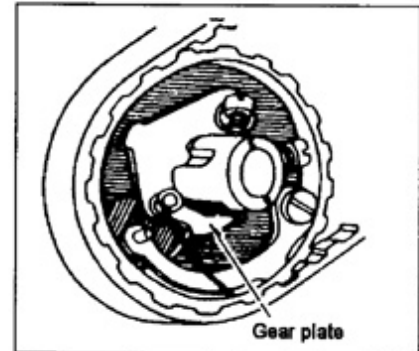
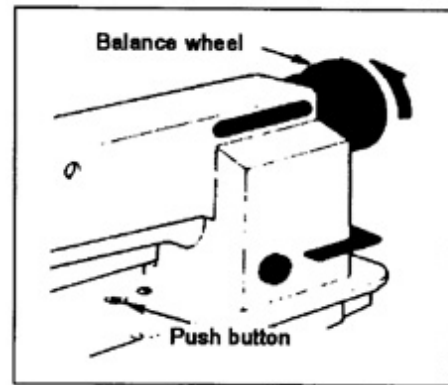

(3) Force applied to the safety clutch.

- a) The force applied to the safety clutch is the smallest when the white mark of the eccentric pin faces the center of the lower shaft. The force proportionally increases as the white mark faces the outside.
- b) To adjust the force slide the timing belt, loosen the set screw, and turn the eccentric pin.
- c) After the adjustment, make sure to fasten the set screw.

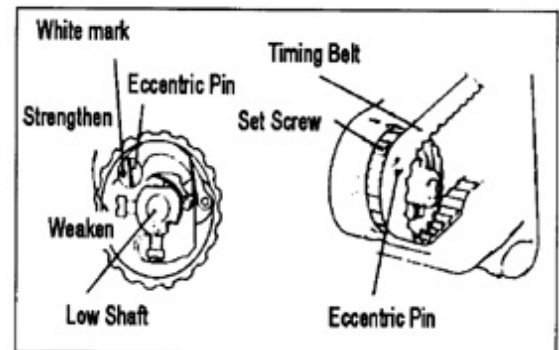

18. Upper feed adjustment

(Needle side)

If the uneven feeding occurs according to the fabric, adjust the long hole of the horizontal feed shaft crank (right) to adjust the upper feed length.

(How to adjust)

- a) Loosen the special bolt.
- b) Move the special bolt upward to decrease upper feed.
- c) Move the special bolt downward to increase the upper feed. The upper feed and the lower feed theoretically becomes equal at the reference line on the horizontal feed shaft crank.
- d) Securely tighten the special bolt after adjustment.

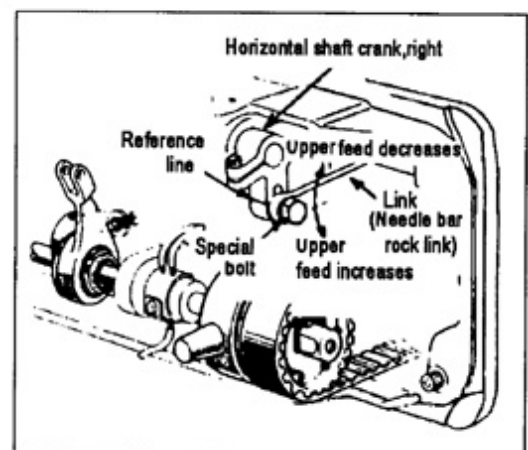

19. Outside presser foot and inside presser vertical stroke adjustment

When fabric with large elasticity is sewn, or when thickness of fabric changes, the vertical stroke (movable range) of the presser feet should be adjusted as follows:

Adjustment

- a) Loosen the special bolt.
 - b) The vertical strokes of the presser feet become
 - c) maximum when the crank rod is moved upward and set.
 - d) The vertical strokes becomes minimum when the nut is moved downward and set.
 - e) After the adjustment, fully tighten the special bolt.
- The vertical strokes of the presser feet can be adjusted within a range from 6mm to 2mm.

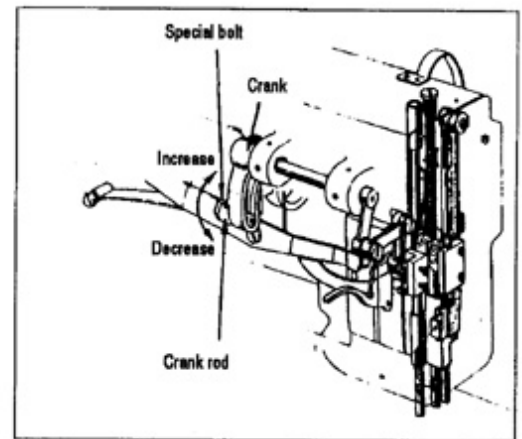

20. Adjustment

Screwing the pin that connects the link of back-sewing with the crank of back-sewing (down) can adjust the tolerance of between the stitches. Screwing the pin in clockwise can increase the stitch of forward sewing; otherwise, the stitch of back-sewing will be increased.

SPECIFICATIONS

Model	GC20618-4	
Number	Four-needle	
Application	Heavy material	
Max. sewing speed	1800(rpm)	
Stitch length	0~9(mm)	
Thread take-up lever stroke	74.5(mm)	
Needle-bar stroke	36(mm)	
Presser-foot stroke	16(mm) by Leg	8(mm) by hand
Vertical stroke of upper feed	2~6(mm)	
Needle No.	DP×17 #23	
Hook	(Horizontal full-rotating) Large	
Thread take-up lever	Slide lever	
Stitch adjusting system	Dial	
Lubrication system	Manual lubrication	
Motor	Servo motor 550W	
Needle gauge	Standard	6.4-6.4-6.4(mm)
	Special	6.4-25.4-6.4(mm)

A.ARM BED AND ITS ACCESSORIES

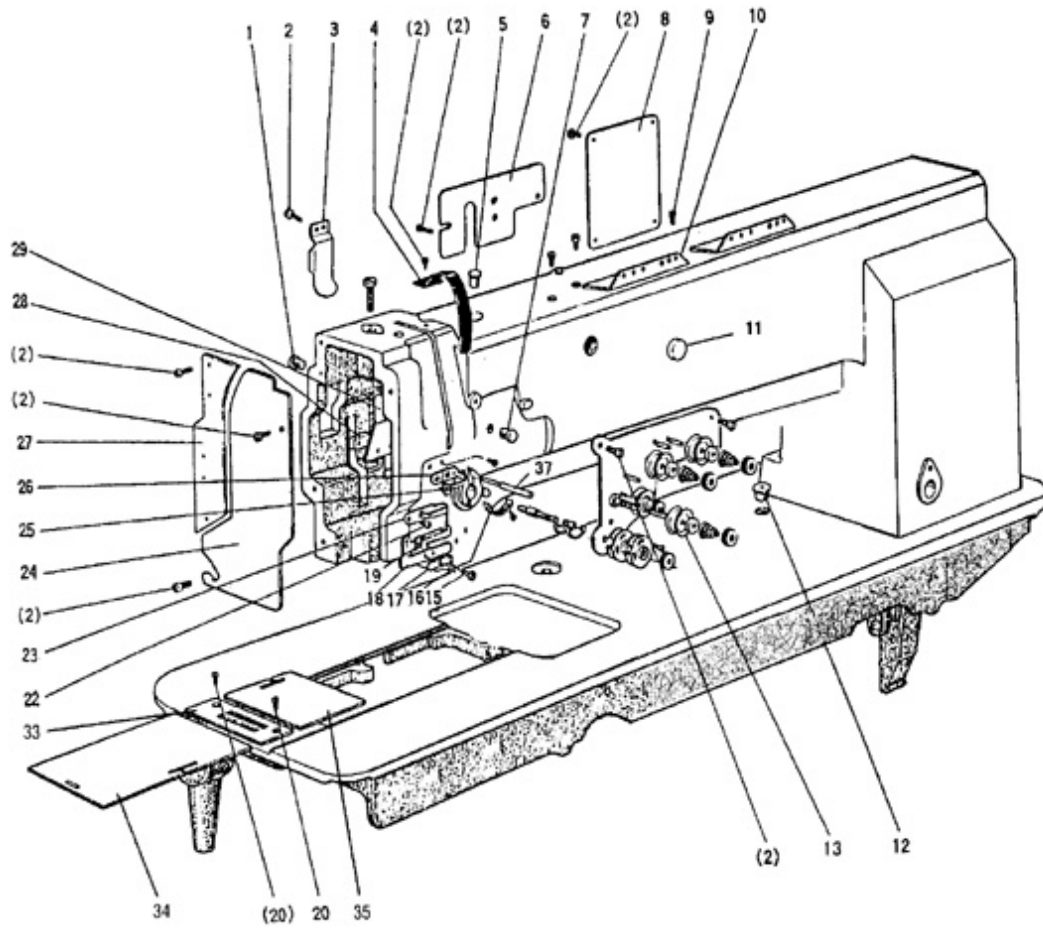

A. ARM BED AND ITS ACCESSORIES

Fig No.	Part. No.	Description	Pcs.	Remarks
A01	HA300B2090	Rubber plug	2	
A02	HA300B2170	Screw	15	SM11/64 (40) × 8
A03	H4716B8001	Oil guard plate	1	
A04	H4717B8001	Thread take-up cover	1	
A05	H4715B8001	Rubber plug	1	φ 13
A06	H4718B8001	Side cover (left)	1	
A07	H2000B2010	Rubber plug	1	φ 13
A08	H4719B8001	Side cover (right)	1	
A09	HA700B2060	Screw	4	SM11/64 (40) × 8
A10	H2400B2100	Thread guide	2	
A12	H2000M0080	Cap	2	
A13	HY80C47101	Thread tension complete	1	
A15	H4722B8001	Screw	1	SM1/8 (44) × 3
A16	H4723B8001	Spring	1	
A17	H4724B8001	Plate	1	
A18	H4725B8001	Thread guide	1	
A19	H3200B2100	Screw	1	SM9/64 (40) × 6.5
A20	HA300B2190	Screw	2	SM11/64 (40) × 8
A22	H3000D2160	Screw	1	SM9/64 (40) × 6.5
A23	H4726B8001	Thread guide (middle)	1	
A24	H4727B8001	Face plate	1	
A25	H2400B2080	Screw	2	SM3/16 (28) × 11
A26	H2400B2070	Thread guide (upper)	1	
A27	HY81E08001	Guide mounting plate	1	
A28	H2400B2060	Plate for oil guard	1	
A29	H3200B2060	Oil guard	1	
A31	H4769E8001	Tension releasing pin	1	
A33	HY81B48001	Needle plate	1	
A34	HY81B28001	Push board left	1	
A35	HY81B38001	Push board right	1	

C.ARM SHAFT MECHANISM

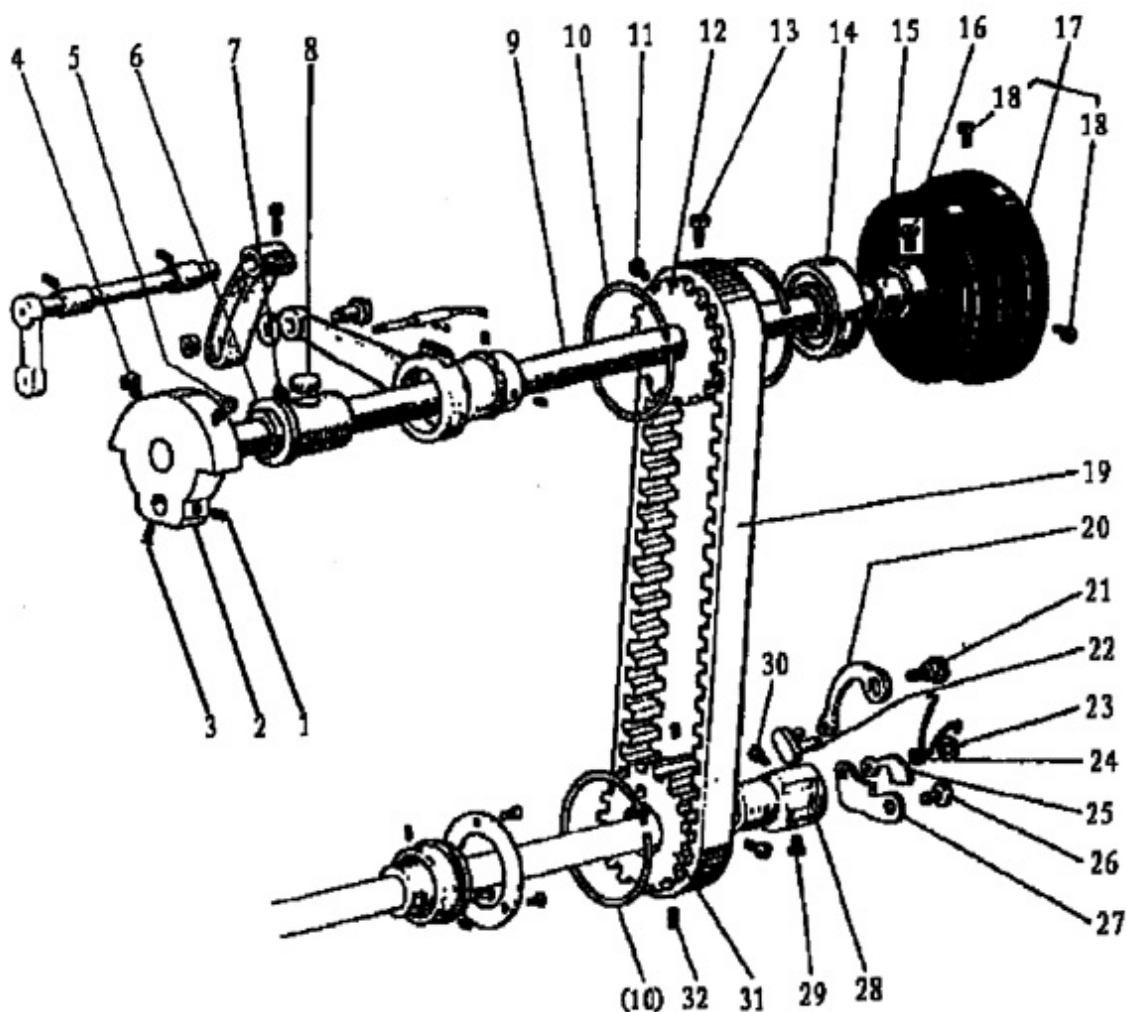

C. ARM SHAFT MECHANISM

Fig No.	Part. No.	Description	Pcs.	Remarks
C01	HA307C0662	Set screw	1	SM1/4 (40) × 7
C02	H4706D8001	Crank	1	
C03	HA105D0662	Screw	1	SM1/4 (40) × 3.5
C04	HA100C2060	Set screw	1	SM9/32 (28) × 14
C05	HA100C2070	Screw	1	SM9/32 (28) × 13
C06	H32111B204	Arm shaft bushing (left)	1	
C07	H4708D8001	Screw	1	SM1/4 (24) × 13
C08	H32111B104	Felt	1	
C09	H4709D8001	Arm shaft	1	
C10	H3205C0661	Spring flange	3	
C11	HA113F0684	Screw	1	SM15/64 (28) × 8.5
C12	H3205C1021	Belt pulley (upper)	1	
C13	HA100F2130	Screw	1	SM15/64 (28) × 14.5
C14	H3205J0662	Bearing	1	
C15	H3205J0661	Collar	1	
C16	HA113F0684	Screw	2	SM15/64 (28) × 8.5
C17	H4711D8001	Pulley	1	
C18	HA110D0672	Screw	2	SM11/64 (28) × 12
C19	H3200C2030	Cog belt	1	
C20	H4713D8001	Spring plate	1	
C21	H4714D8001	Pin	1	
C22	H4715D8001	Link	1	
C23	H007013025	E-type stop ring	1	GB/T896 2.5
C24	H4716D8001	Twist spring	1	
C25	H4717D8001	Plate	1	
C26	H4718D8001	Pin	1	
C27	H4719D8001	Plate	1	
C28	H4720D8001	Bushing	1	
C29	H4721D8001	Screw	1	SM15/64 (28) × 10.5
C30	HA104F0654	Screw	1	SM15/64 (28) × 10
C31	H4722D8001	Belt pulley (lower)	1	
C32	H4723D8001	Screw	2	SM15/64 (28) × 4.5

D. UPPER SHAFT & PRESSER FOOT MECHANISM

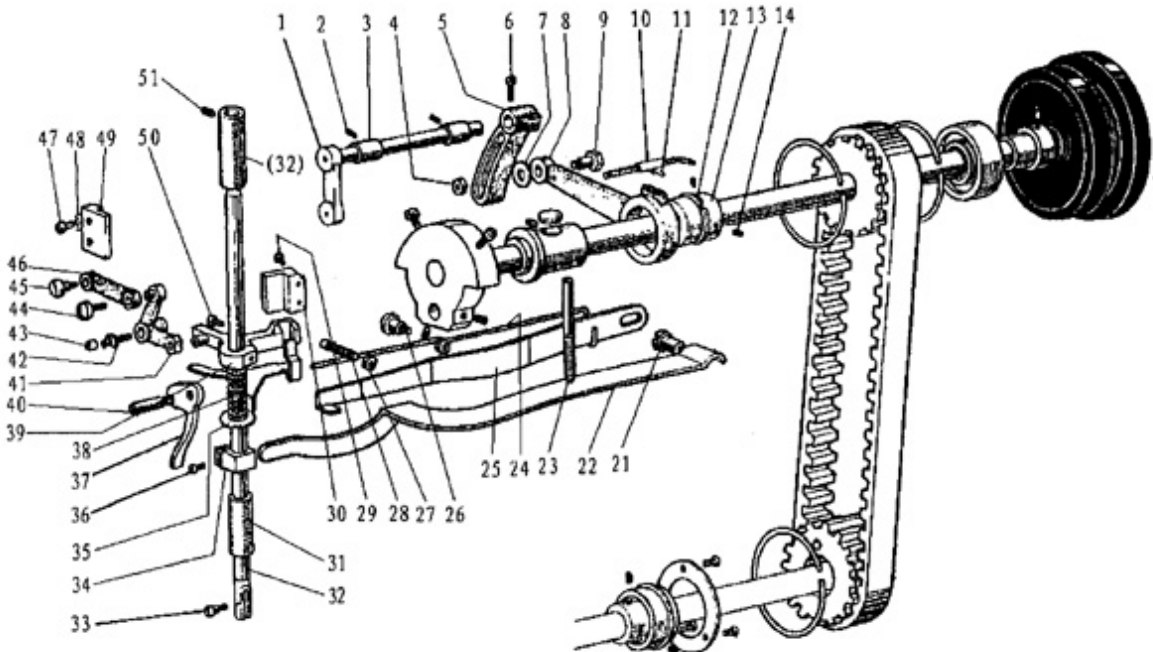

D. UPPER SHAFT & PRESSER FOOT MECHANISM

Fig No.	Part. No.	Description	Pcs.	Remarks
D01	H4705E8001	Feed lifting rock shaft	1	
D02	H4706E8001	Screw	2	SM1/4 (24) × 7
D03	H4707E8001	Bushing	2	
D04	HS91165206	Nut	1	M6 × 0.75
D05	H4709E8001	Lever	1	
D06	H3115F0671	Screw	1	SM1/4 (28) × 16
D07	H2013J0065	Washer	1	
D08	H2014J0066	Connecting rod	1	
D09	H2000J2100	Bolt	1	
D10	H4713E8001	Oil pipe & wick complete	1	
D11	H20111C106	Spring	1	
D12	H007009250	C-type stop ring	1	GB/T894.1 25
D13	H4714E8001	Eccentric	1	
D14	HA307C0662	Screw	2	SM1/4 (40) × 6
D21	H3100G2170	Screw	1	SM1/4 (24) × 17
D22	H4730E8001	Lever spring	1	
D23	H4729E8001	Screw	1	SM15/64 (28) × 79
D24	H4727E8001	Twist spring	1	
D25	H4728E8001	Knee lifting lever	1	
D26	H3100G2130	Screw	1	SM1/4 (24) × 7
D27	H4726E8001	Nut	1	
D28	H4725E8001	Screw	1	SM1/4 (24) × 19
D29	HA111G0683	Screw	2	SM11/64 (40) × 12
D30	H4723E8001	Guide	1	
D31	H4744E8001	Bushing	1	
D32	H4754E8001	Presser bar	1	
D33	H3200E2020	Screw	1	SM1/8 (44) × 9
D34	H4746E8001	Spring bracket	1	
D35	H4768E8001	Thread releasing plate	1	
D36	H2404I0034	Screw	1	SM9/64 (40) × 8.5
D37	H4748E8001	Lifter lever	1	
D38	H4767E8001	Spring	1	
D39	H4752E8001	Bracket	1	
D40	H4749E8001	Screw	1	SM11/64 (40) × 8.5
D41	H4715E8001	Bell crank	1	
D42	H2004J0655	Support shaft	1	
D43	H4717E8001	Roller	1	
D44	H4718E8001	Screw	1	SM11/64 (32) × 6
D45	H2004J0662	Screw	1	SM1/4 (40) × 5
D46	H4719E8001	Link	1	
D47	HA100E2150	Screw	2	SM11/64 (40) × 10
D48	H4722E8001	Washer	2	
D49	H4721E8001	Bell crank guide	1	
D50	H4753E8001	Screw	1	SM11/64 (40) × 14.5
D51	H4708D8001	Screw	2	SM1/4 (24) × 13

E. TAKE-UP THREAD AND ARM SHAFT MECHANISM

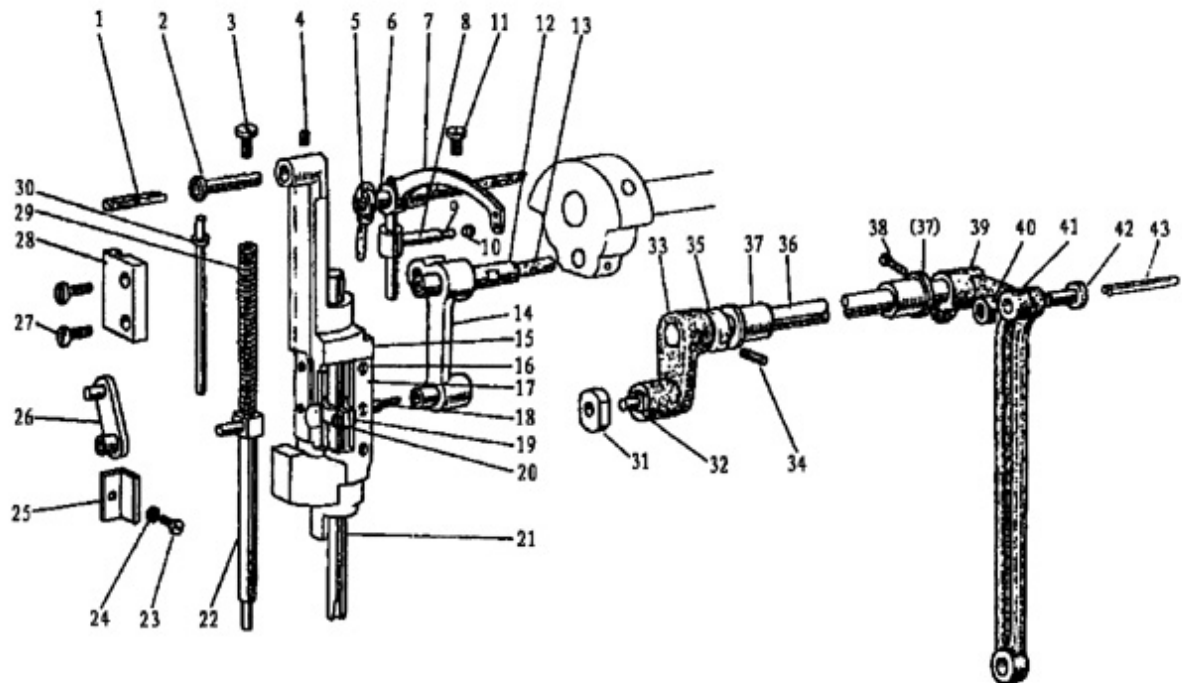

E. TAKE-UP THREAD AND ARM SHAFT MECHANISM

Fig No.	Part. No.	Description	Pcs.	Remarks
E01	H24211DN05	Oil wick	1	
E02	H4706F8001	Needle bar guide bracket stud	1	
E03	H4707F8001	Screw	1	SM5/16 (28) × 10.4
E04	HA100C2020	Screw	1	SM15/64 (28) × 10
E05	H24211DN05	Oil wick	1	
E06	H24211DM05	Thread take-up lever support stud	1	
E07	H4712F8001	Thread take-up lever	1	
E08	H2405D1112	Thread take-up slide brock	1	
E09	H24211D405	Oil wick	1	
E10	H24211D305	Plug	1	
E11	HA110D0672	Screw	1	SM15/64 (28) × 12
E12	H2405D0662	Needle bar crank pin	1	
E13	H4716F8001	Oil wick	1	
E14	H4717F8001	Connecting link	1	
E15	H4719F8001	Needle bar guide bracket	1	
E16	H32111D304	Screw	6	SM3/32 (56) × 4
E17	H4721F8001	Spacer	2	
E18	H3204D6513	Felt	1	
E19	H4722F8001	Needle bar holder	1	
E20	H32111D604	Screw	1	SM9/64 (40) × 8.5
E21	H4724F8001	Needle bar	1	
E22	H4725F8001	Vibrating presser bar	1	
E23	H3400C2020	Screw	1	
E24	H3200I2030	Washer	1	
E25	H3400C2010	Needle bar guide	1	
E26	H4726F8001	Vibrating presser bar link	1	
E27	H4753E8001	Screw	2	SM11/64 (40) × 17.5
E28	H4728F8001	Vibrating presser bar guide	1	
E29	H4729F8001	Spring	1	
E30	H4730F8001	Vibrating presser spring guide	1	
E31	H3410C301P	Square block	1	
E32	H3406C0671	Crank pin	1	SM15/64(28) × 10
E33	H3406C0672	Needle bar vibrating crank (left)	1	
E34	H602040240	Taper	1	GB/T117 4×24
E35	H4734F8001	Collar	1	
E36	H4736F8001	Needle bar vibrating shaft	1	
E37	H3204B0652	Needle bar vibrating shaft bushing	2	
E38	H2012N0652	Screw	1	SM1/4 (24) × 16
E39	H3407C0661	Needle bar vibrating crank (right)	1	
E40	H32311D506	Nut	1	
E41	H3407C0662	Connecting link	1	
E42	H32311D306	Screw	1	SM5/16(24)
E43	H32311D406	Oil wick	1	

F. STITCH REGULATOR MECHANISM

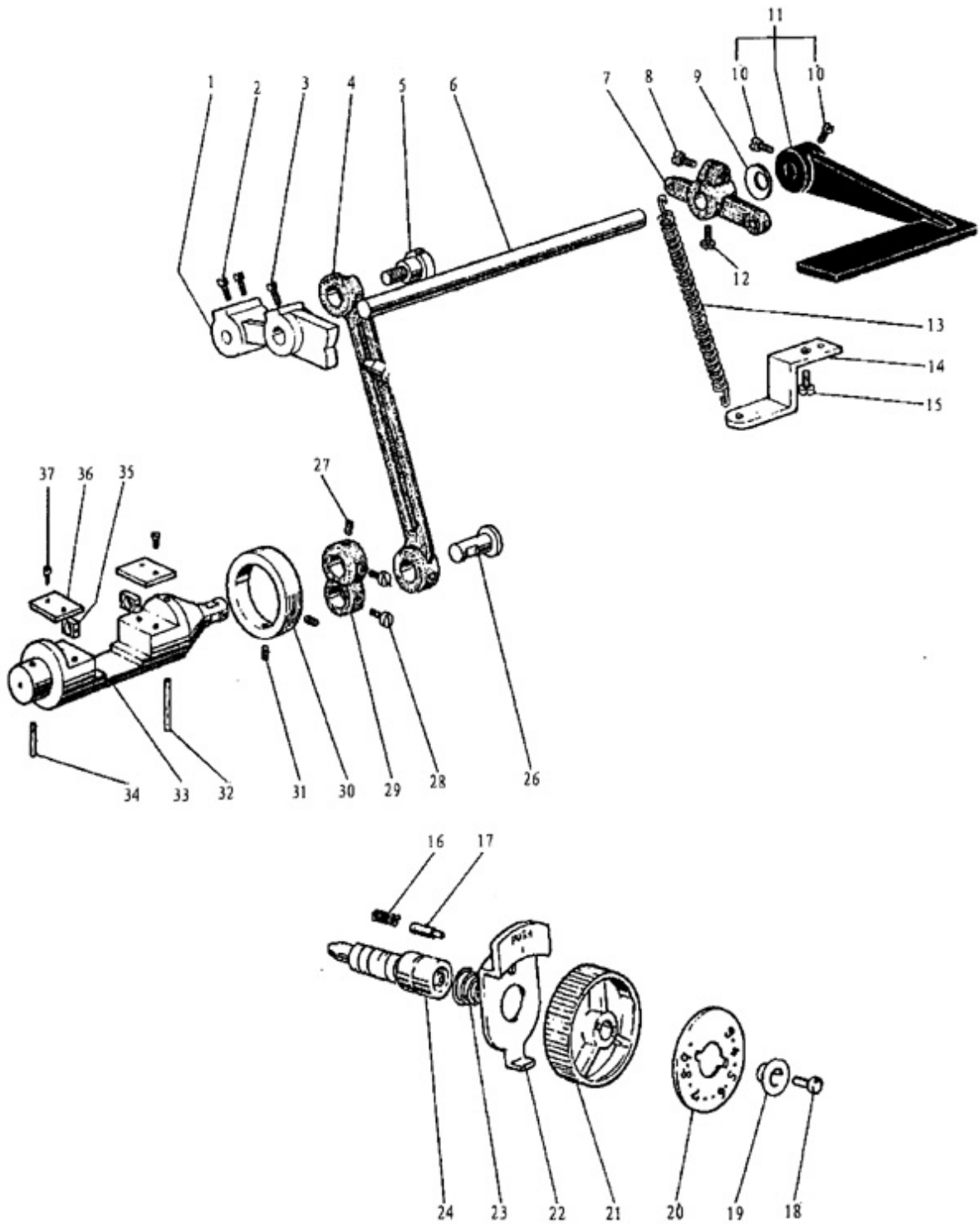

F. STITCH REGULATOR MECHANISM

Fig No.	Part. No.	Description	Pcs.	Remarks
F01	H4706G8001	Feed regulator cam	1	
F02	HA113F0684	Screw	2	SM15/64 (28) × 8.5
F03	H3200F2020	Screw	1	SM15/64 (28) × 12
F04	H4707G8001	Link	1	
F05	HA100G2070	Eccentric shaft	1	
F06	H4709G8001	Reverse stitch shaft (upper)	1	
F07	H3207F0671	Arm	1	
F08	HA800F2020	Screw	1	
F09	HA100F2110	Spring Washer	1	
F10	HA113F0684	Screw	2	
F11	H4711G8001	Reverse sewing lever	1	
F12	H3207F0672	Screw	1	SM11/64 (40) × 8.5
F13	H4710G8001	Spring	1	
F14	H3200F2050	Guide plate	1	
F15	HA300C2030	Screw	1	SM11/64 (40) × 8
F16	H3200F2110	Spring	1	
F17	HA700F2030	Pin	1	
F18	HA720F0686	Screw	1	SM3/16 (28) × 18
F19	HA720F0685	Bushing	1	
F20	H4910G8001	Stitch length indicating plate	1	
F21	HA7421F120	Dial	1	
F22	HA720F0683	Stopper pin releasing lever	1	
F23	HA720F0687	Coil spring	1	
F24	HA109F0671	Screw bar	1	
F25	H3206F0662	Pin	1	
F26	H415050200	Screw	1	GB/T70.1 M5 × 20
F27	H428050060	Screw	2	GB/T77 M5 × 6
F28	H4714G8001	Reverse sewing crank	1	
F29	H4715G7101	Collar	1	
F30	HA3411D308	Screw	2	SM15/64" (28) × 7
F31	H4719G8001	Felt	1	
F32	H4720G8001	Rverse block	1	
F33	H4721G8001	Felt	1	
F34	H4722G8001	Square block	2	
F35	H4723G8001	Guide plate	2	
F36	HA300C2030	Screw	4	SM11/64 (40) × 8
F37	H3204B0652	Needle bar vibrating shaft bushing	2	

G.LOWER SHAFT & FEED ROCK SHAFT MECHANISM

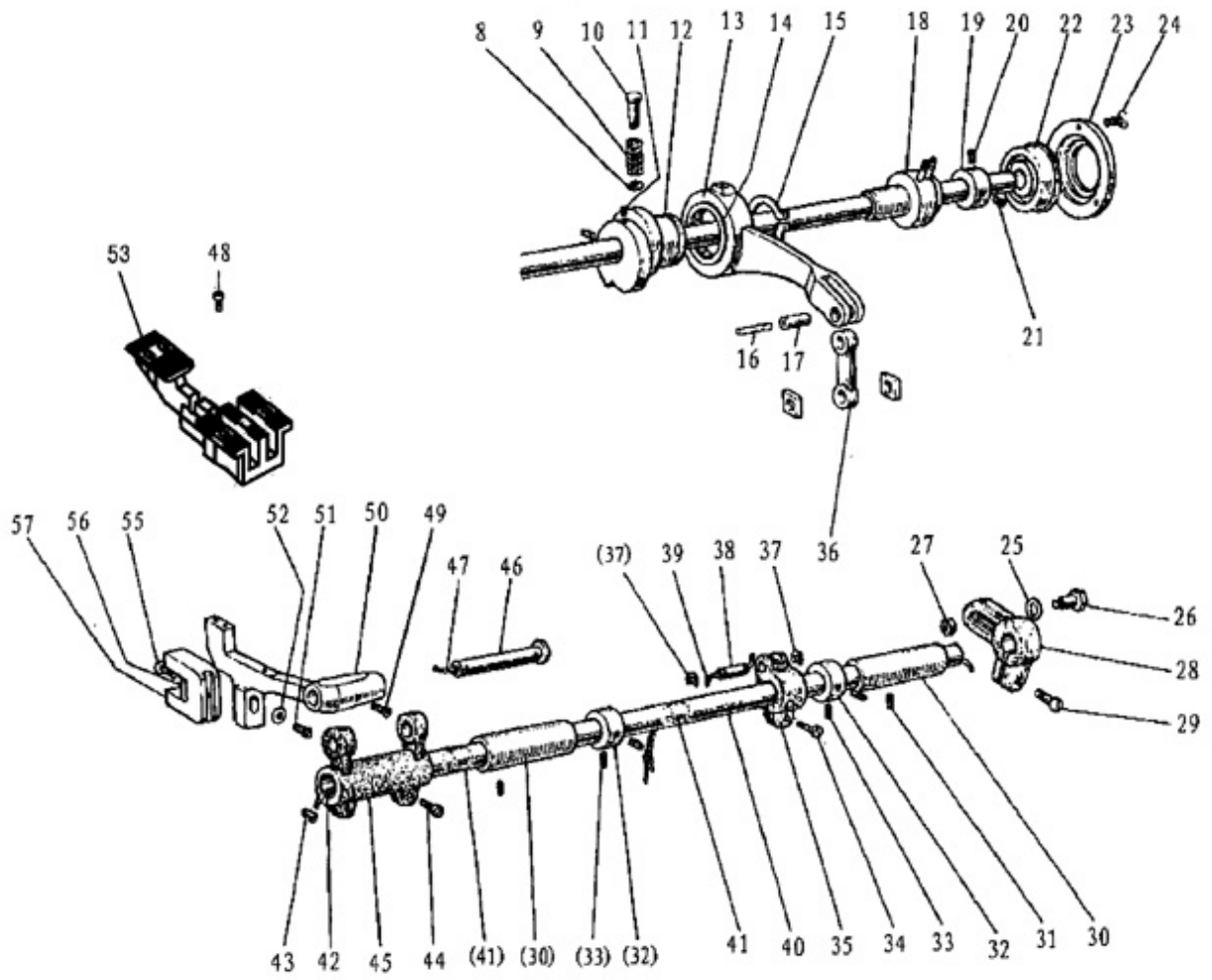

G. LOWER SHAFT & FEED ROCK SHAFT MECHANISM

Fig No.	Part. No.	Description	Pcs.	Remarks
G08	H007013050	Stop ring	2	GB/T896 5
G09	H4714H8001	Spring	1	
G10	H4715H8001	Push button	1	
G11	H2405D0664	Screw	2	SM15/64 (28) × 14
G12	H4717H8001	Feed eccentric	1	
G13	H4718H8001	Feed connecting rod	1	
G14	H4719H8001	Needle bearing	1	
G15	H007009260	C-type stop ring	1	GB/T894.1 26
G16	H4720H8001	Oil wick	1	
G17	H4721H8001	Shaft	1	
G18	H4722H7101	Lower shaft bushing complete (middle)	1	
G19	H4725H8001	Bushing	1	
G20	HA105D0662	Screw	1	SM1/4 (40) × 4
G21	H3205H0654	Screw	1	SM1/4 (40) × 5
G22	H4723H8001	Ball bearing	1	
G23	H4727H8001	Bearing holder	1	
G24	HA7311C306	Screw	3	SM9/64 (40) × 7
G25	H4728H8001	Washer	1	
G26	H4729H8001	Screw	1	M6
G27	H003055060	Nut	1	GB52008 M6
G28	H4731H8001	Feed connection crank (right)	1	
G29	H2012N0652	Screw	1	SM1/4 (24) × 16
G30	HA100G2120	Feed rock shaft bushing	2	
G31	H4708D8001	Screw	2	SM1/4 (24) × 13
G32	HA108G0661	Collar	2	
G33	HA105D0662	Screw	4	1/4(40)×4
G34	H2012N0652	Screw	1	SM1/4 (24) × 16
G35	H4736H8001	Feed connection crank (middle)	1	
G36	H4737H8001	Link	1	
G37	H007013050	E-type stop ring	2	GB/T896 5
G38	H4738H8001	Pin	1	
G39	H4739H8001	Oil wick	1	
G40	H3204G0651	Feed rock shaft	1	
G41	H4740H8001	Felt	2	
G42	H3204G0031	Oil wick	1	
G43	H3200G2030	Clip	1	
G44	HA104G0012	Screw	2	SM3/16 (28) × 12
G45	H3205G1032	Feed connection crank (left)	1	
G46	H32243G205	Feed bar shaft	1	
G47	H3205G0662	Oil wick	1	
G48	H32211G205	Bolt	2	SM1/8 (40) × 7
G49	H429050050	Bolt	1	GB/T78 M5×5
G50	HY80H58001	Feed bar	1	
G51	H3200H2040	Screw	1	SM15/64 (28) × 17
G52	H2013J0065	Washer	1	
G53	HY80H48001	Feed	1	
G55	H3205H0653	Screw	1	SM1/8 (44) × 4
G56	H3205H0652	Felt	1	
G57	H4743H8001	Feed bar forked connection	1	

H.HOOK SADDLE MECHANISM

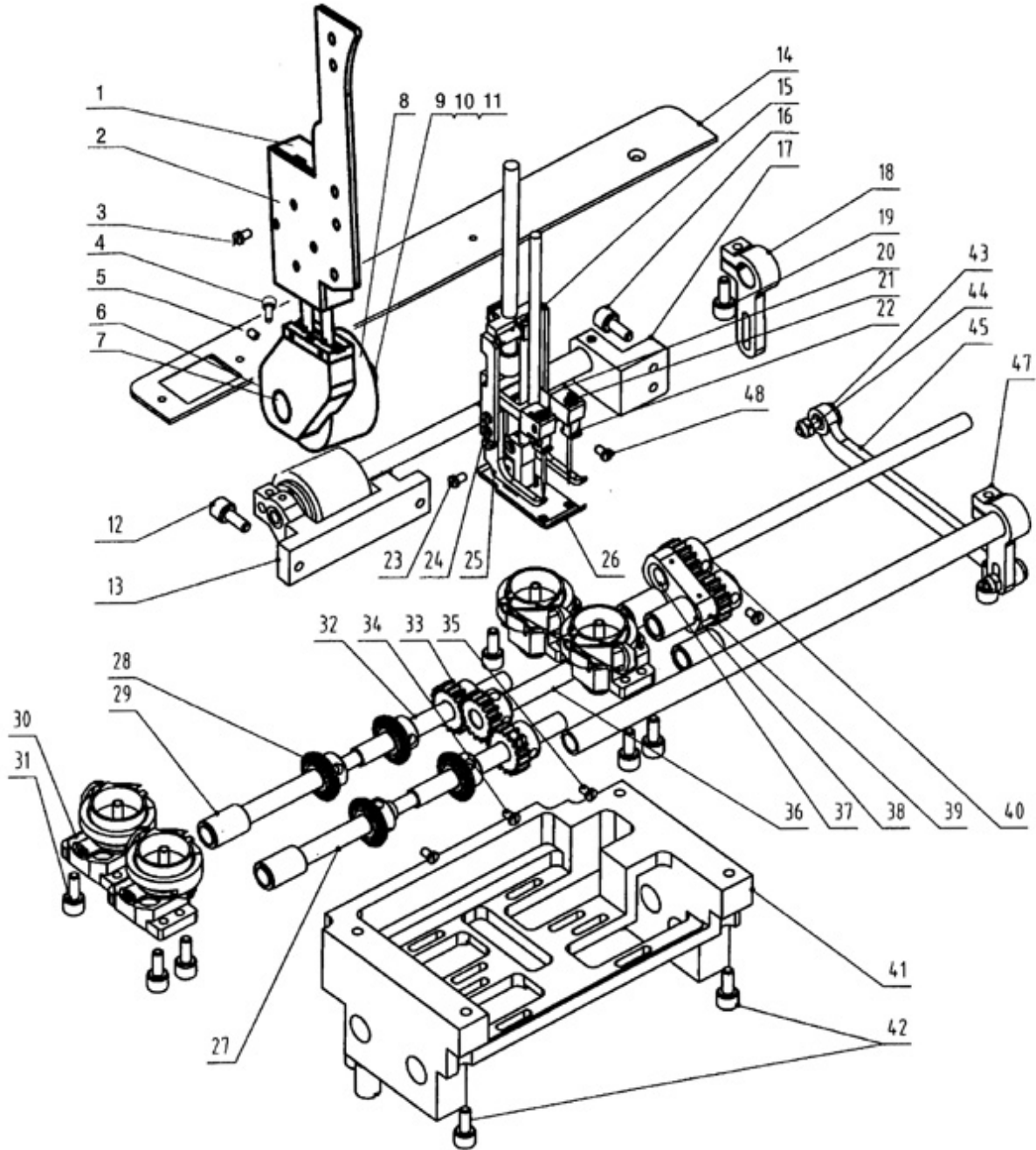

H. HOOK SADDLE MECHANISM

Fig No.	Part. No.	Description	Pcs.	Remarks
H01	HY80J98001	Cylinder	1	SSA 12×10-B
H02	H415050120	Panel	1	
H03	HY80J68001	Screw	4	
H04	HF831H8001	Screw	2	
H05	H415050160	Screw	1	
H06	HY80J58001	Install the seat	1	
H07	H003045050	Shaft	1	
H08	HY81J08001	Mop wheel	1	
H09	HF845H7101	Gasket	2	
H10	HY80J88001	Retaining ring	1	
H11	HY80J78001	Screw	1	
H12	H415050200	Screw	2	
H13	HE70407101	Wheel installation frame components	1	
H14	HE71308001	Hinge cover plate	1	
H15	HY80E58001	Stents	1	
H16	H415050100	Screw	2	
H17	HE70608001	Stents	1	
H18	HG01K07101	Crank (long) components	1	
H19	H3208G0676	Screw	1	
H20	HY80F68001	Needle clamp mounting plate	1	
H21	H3205H0653	Screw	4	
H22	H3410C3013	Needle holder 1/4	4	
H23	HA700F2100	Screw	1	
H24	H4967K8001	Screw	6	
H25	HY80E48001	Presser foot	2	
H26	HY81F17101	Presser foot components	1	
H27	HY80G68001	Gear shaft 1	1	
H28	HE110D8001	Shaft bevel gear	4	
H29	HY80I68001	Shaft sleeve	5	
H30	HY80I58001	Hook sets	4	
H31	H415050180	Screw	8	
H32	HY80G88001	Gear shaft 3	1	
H33	HY80G48001	Gear	4	
H34	HE051C8001	Screw	8	
H35	HA105D0662	Screw	10	
H36	HY80G78001	Gear shaft 2	1	
H37	HY80I88001	Shaft sleeve 1	1	
H38	HY80I98001	Shaft sleeve 2	1	
H39	HY80I78001	Fixed block	1	
H40	HY80G58001	Gear	1	
H41	HY80I48001	Install the seat	1	
H42	H415060200	Screw	4	
H43	HE71008001	Screw	2	
H44	H4940L8001	Nut	2	
H45	H3407C0662	Connecting rod	1	
H47	HY81J18001	Crank	1	
H48	H431040060	Screw	2	

J.ACCESSORIES

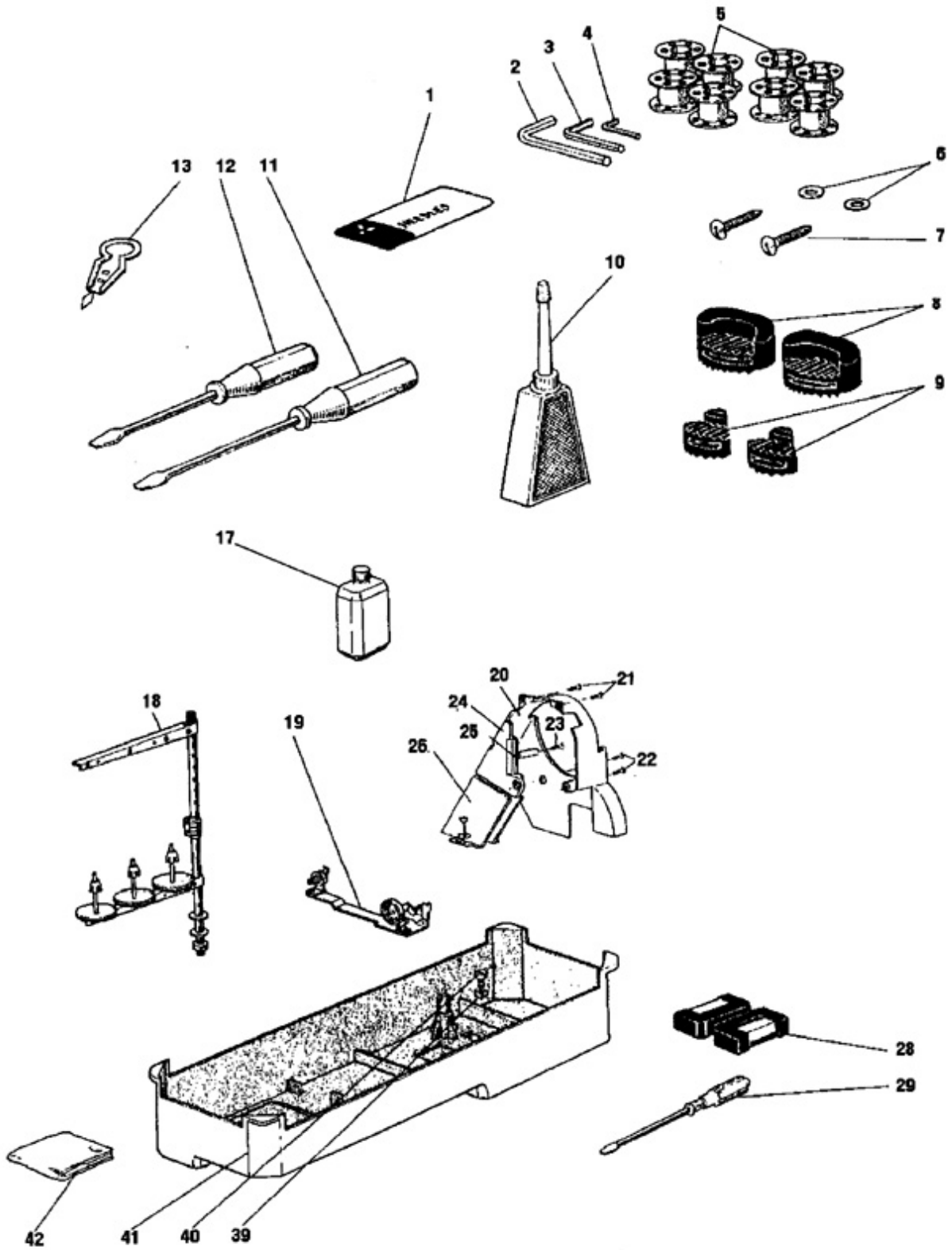

J. ACCESSORIES

Fig No.	Part. No.	Description	Pcs.	Remarks
J01	H4740F8001	Needle DP×17-23	12	
J02	H3209L8001	Socket wrench	1	
J03	H3208L8001	Socket wrench	1	
J04	H4905N8001	Socket wrench	1	
J05	HD806I8001	Bobbin	8	
J06	H3200L0050	Screw	2	
J07	H801045200	Vibration preventing rubber	4	GB/T99 4.5×20
J08	H4700K0020	Vibration preventing rubber	2	
J09	H4700K0030	Vibration preventing rubber	2	
J10	HA100J2110	Oiler	1	
J11	HA100J2140	Screw driver (middle)	1	
J12	HA100J2150	Screw driver (small)	1	
J13	H3207L0065	Thread a needle kit	1	
J17	H3200L0130	Oil can	1	
J18	HF806L8001	Cotton stand	1	
J19	H3300L0040	Bobbin winder	1	
J20	H200800068	Belt cover	1	
J21	HA300C2170	Screw	1	SM11/64(40)×8
J22	HA300J2280	Screw	2	SM11/64(28)×8
J23	HA300J2250	Screw	1	M4×8
J24	H2405K6601	Belt cover complete	1	
J25	H003008040	Nut	1	GB/T6172.1 M4
J26	HA305J0665	Belt cover	1	
J28	HA307J0671	Hinge complete	2	
J29	HA300J2070	Screw driver (large)	1	
J39	HA104J0653	Washer	1	
J40	HA104J0652	Screw	1	
J41	HY80L58001	Oil reservoir	1	
J42	HA100J2180	Vinyl cover	1	

SHANGHAI HUIGONG NO.3 SEWING MACHINE FACTORY

ADD: No.850, ShuLin Road, SongJiang District, Shanghai, P.R. China

Zip Code: 201612

Overseas Business: TEL: 86-21-64853303 FAX: 86-21-64854304

E-mail: highlead@online.sh.cn <http://www.highlead.com.cn>

The description covered in this manual is subject to change for improvement of the commodity without notice

2019.6. Printed