



**HIGHLEAD**

**GC20018-4**

**Four-needles, Lockstitch Sewing Machine**

**Parts Catalog**

**SHANGHAI BIAOZHUN HAILING SEWING MACHINERY CO., LTD.**

## A.ARM BED AND ITS ACCESSORIES

---

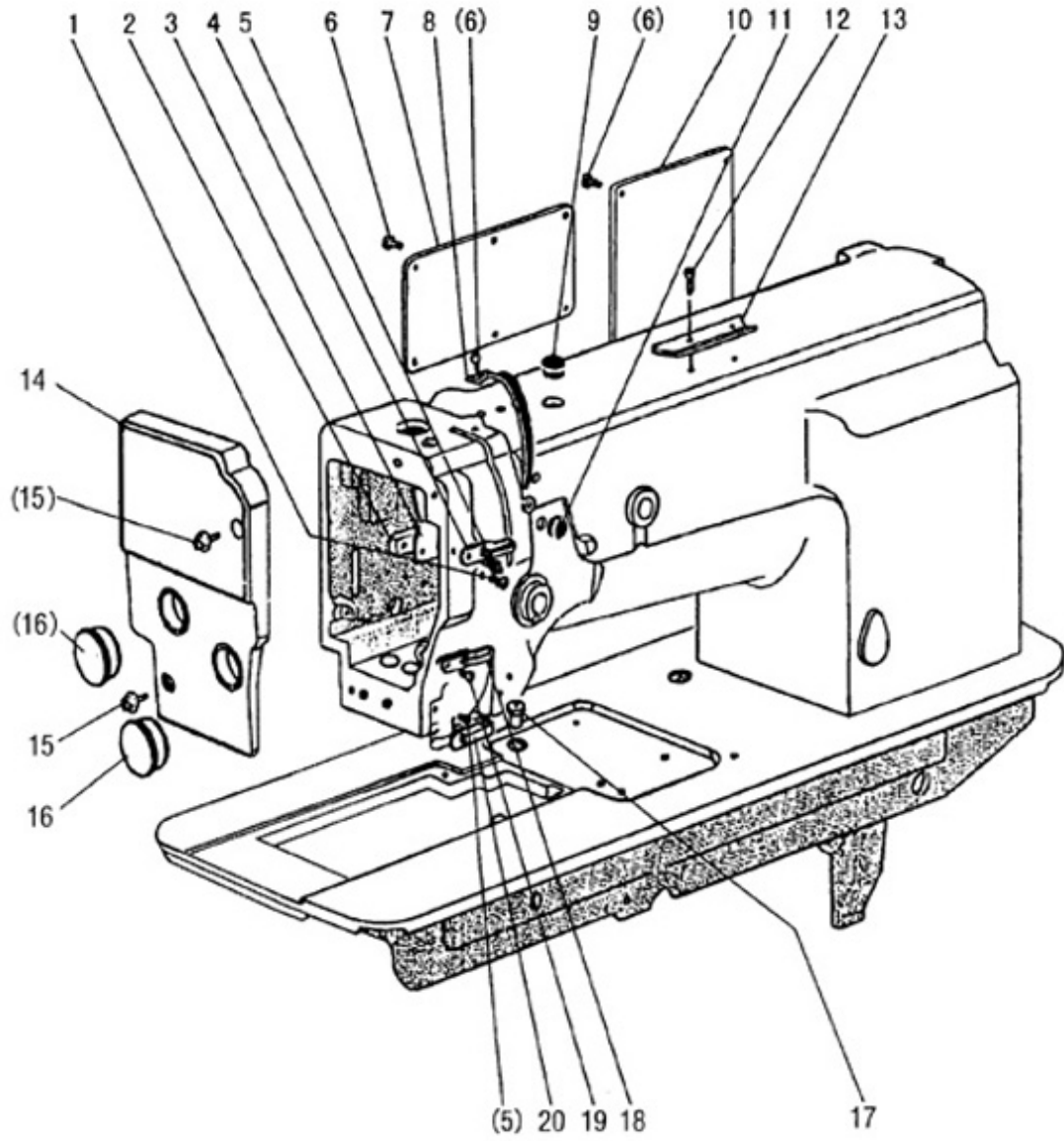

A. ARM BED AND ITS ACCESSORIES

Fig No.	Part. No.	Description	Pcs.	Remarks
A01	H3000D2160	Screw	2	
A02	H2400B2060	Spacer	1	
A03	H2400B2050	Oil guard plate	1	
A04	H3200B2070	Thread guide	1	
A05	H2400B2080	Screw	1	
A06	HA300B2170	Screw	11	
A07	H3200B2030	Side cover (left)	1	
A08	H3200B2050	Thread take-up cover	1	
A09	H2400J2010	Oil cap	1	Φ 13
A10	H3200B2040	Side cover (right)	1	
A11	H2000B2010	Pubber plug	1	Φ 13
A12	HA700B2060	Screw	2	SM11/64 (40) × 10
A13	H2400B2100	Thread guide	1	
A14	H3200B2020	Face plate	1	
A15	HA300B2160	Screw	2	
A16	HA307B0673	Pubber plug	2	Φ 19
A17	HE015L8001	Cap	1	
A18	HF814B8001	Thread guide	1	
A19	HE032B8001	Screw	1	
A20	H3212B0066	Thread guide complete	1	

## B.THREAD TENSION REGULATOR MECHANISM

---

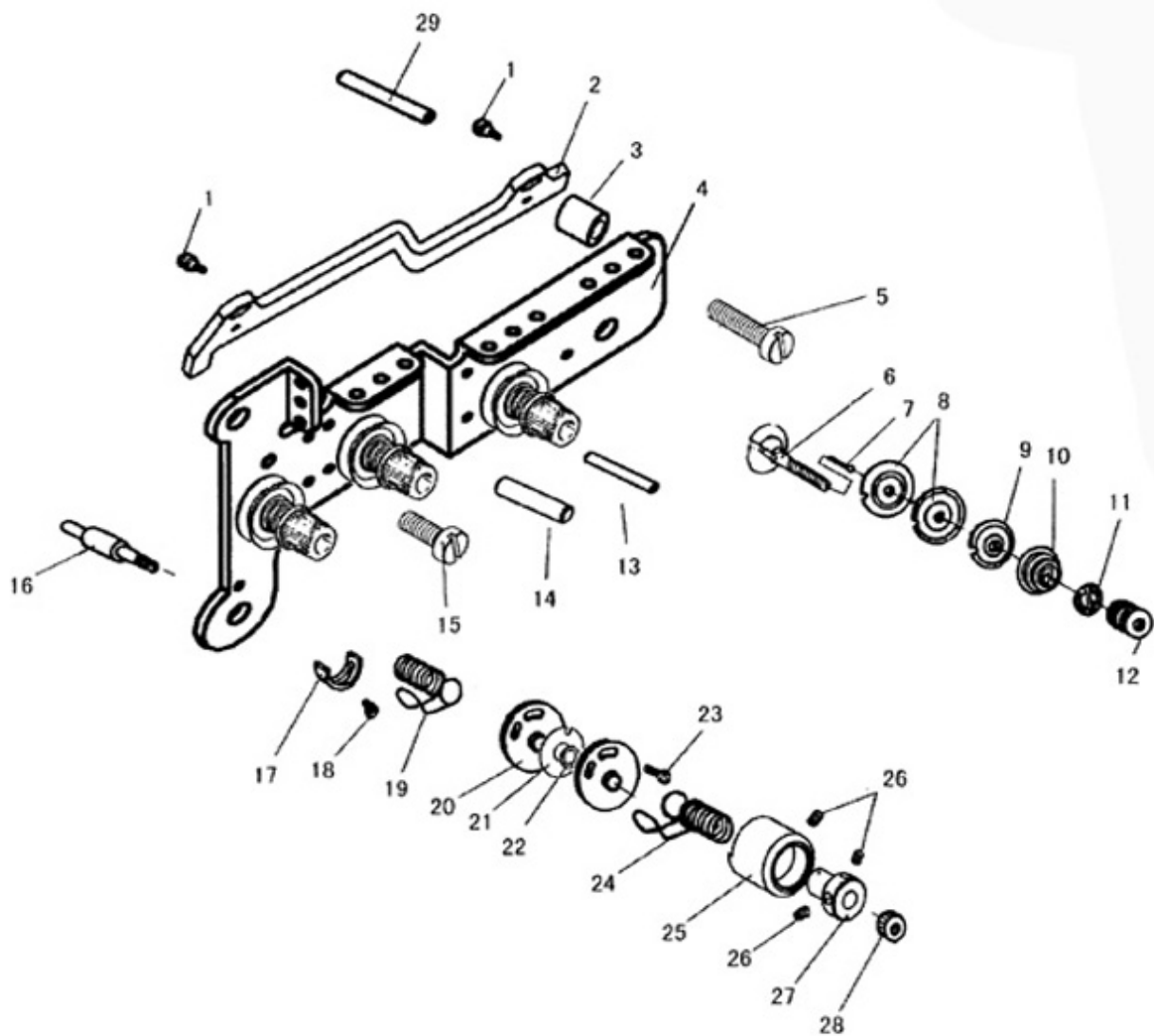

B. THREAD TENTION REGULATOR MECHANISM

Fig No.	Part. No.	Description	Pcs.	Remarks
B01	HE019K8001	Screw	2	
B02	HF808J8001	Tention Release Plate	1	
B03	H2000N0040	Washer	1	
B04	HF805J8001	Tention Release Plate	1	
B05	H4753E8001	Screw	1	SM11/64 (40) ×17.5
B06	HE007K8001	Tention Release Pin	4	
B07	HE008K8001	Tention Screw	4	
B08	H2504C0656	Tention Disc	8	
B09	H2504C0657	Tention Release Washer	4	
B10	HA115B0703	Tention Spring	4	
B11	HA115B7010	Nut Washer	4	
B12	HA310B0701	Nut	4	
B13	H605020140	Pin	4	
B14	H605020090	Pin	4	
B15	HA100E2150	Screw	1	SM11/64 (40) ×10
B16	HY80C58001	Thread Controller Stod	1	
B17	H3221B6819	Thread Controller Spring Stop	1	
B18	H3200B2100	Screw	1	
B19	HE525K8001	Thread Controller Spring	1	
B20	HE015K7101	Thread Controller Disc	2	
B21	HE524K8001	Thread Controller Position Disc	1	
B22	HE527K8001	Washer	1	
B23	HE530K8001	Screw	1	
B24	HE526K8001	Thread Controller Spring	1	
B25	HE529K8001	Bushing	1	
B26	H6039G8001	Screw	3	
B27	HE528K8001	Thread Controller Spring Bushing	1	
B28	HE017K8001	Nut	1	
B29	H3221B6818	Tention Release Plate Roo	1	

# C.ARM SHAFT & PRESSER FOOT MECHANISM

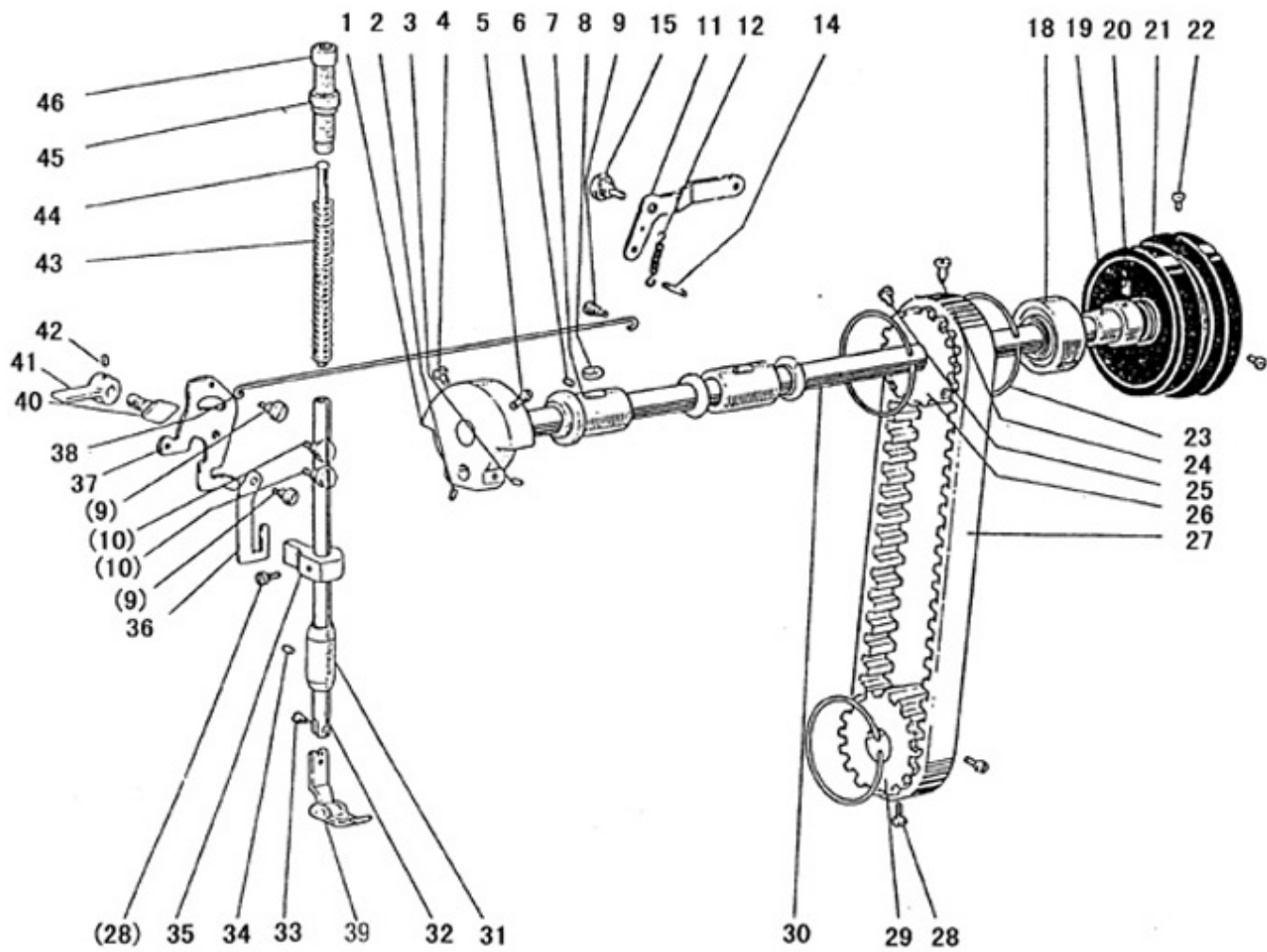

C. ARM SHAFT & PRESSER FOOT MECHANISM

Fig No.	Part. No.	Description	Pcs.	Remarks
C01	H32121C104	Needle bar crank complete	1	
C02	HA105D0662	Screw	1	
C03	HA307C0662	Screw	1	
C04	HA100C2070	Screw	1	
C05	HA100C2060	Screw	1	
C06	H2405D0664	Screw	1	
C07	H32111B204	Arm shaft bushing left	1	
C08	H32111B104	Felt	1	
C09	HA107H0662	Screw	2	
C10	HA100H2050	Screw	3	
C11	HFE4078001	Knee lifter lever (right)	1	
C12	H3211E0692	Spring	1	
C14	H3200E2090	pin	1	
C15	HB2259J081	Screw	1	
C18	H3205J0662	Ball bearing	1	
C19	H3205J0661	Bushing	1	
C20	HA113F0684	Screw	2	
C21	H4711D8001	Pulley	1	
C22	HA110D0672	Screw	2	
C23	H3205C0661	Spring flange	3	
C24	HA110D0672	Screw	1	
C25	HA100F2130	Screw	1	
C26	H3205C1021	Pulley	1	
C27	H3200C2030	Cog belt	1	
C28	HA104F0654	Screw	1	
C29	HFG4047101	Pulley	1	
C30	H3204C0651	Arm shaft	1	
C31	HH408E8001	Bushing	1	
C32	HFE4048001	Presser bar	1	
C33	H3200E2020	Screw	1	
C34	H2405D0664	Screw	1	
C35	H3207E0661	Presser bar guide bracket	1	
C36	H3210E0683	Operation plate	1	
C37	H3210E0682	Knee lifter lever (left)	1	
C38	H6705Q8001	Knee lifter rod	1	
C40	H3200E2060	Presser bar lifting cam	1	
C41	H3208E0672	Presser bar lifter complete	1	
C42	HA100B2110	Screw	2	
C43	H3200E2100	Spring	1	
C44	HA100H2120	Presser spring guide	1	
C45	HA117H0692	Special nut	1	
C46	HA309H0681	Thumb nut	1	

# D.TAKE-UP THREAD AND ARM SHAFT MECHANISM

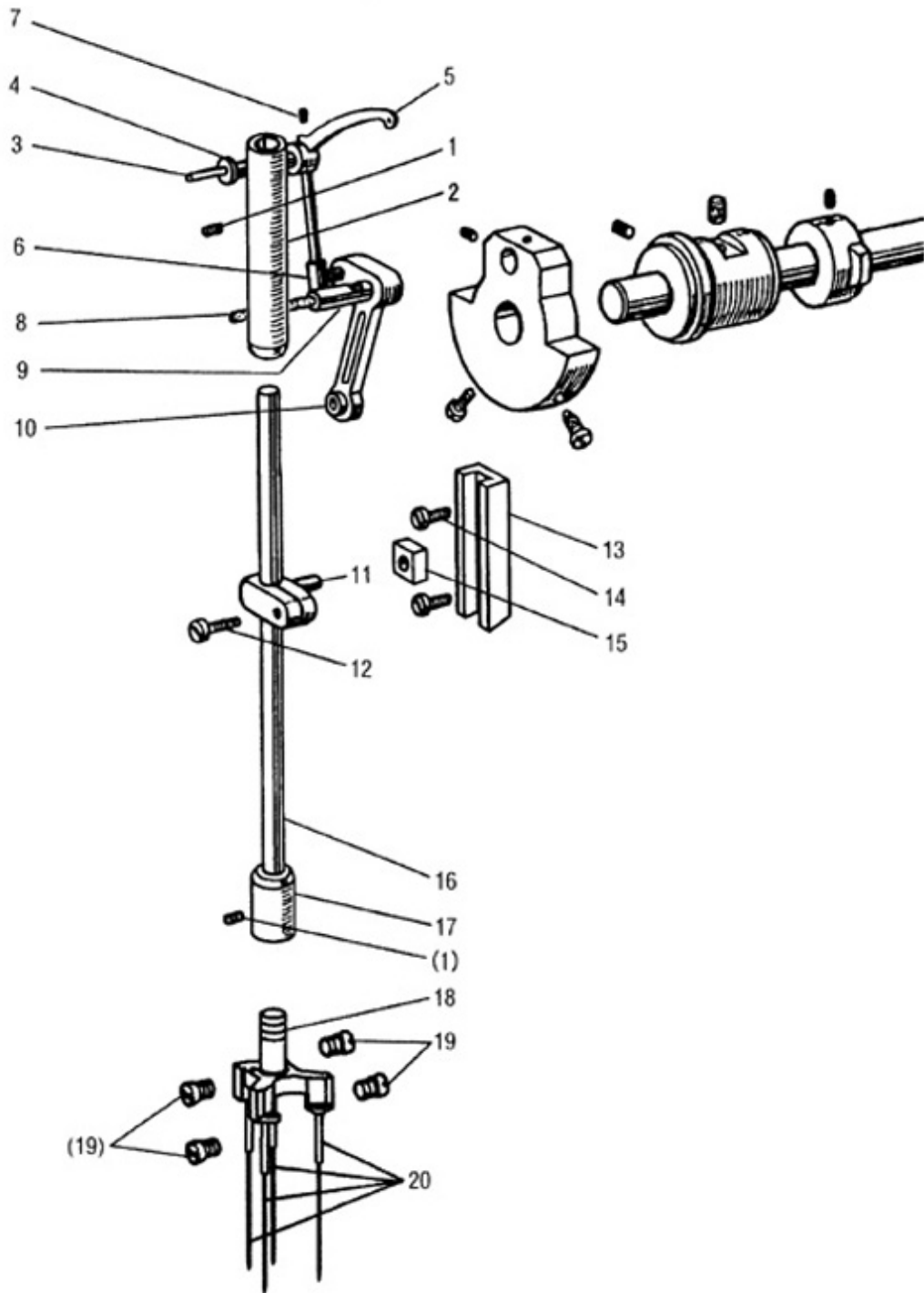



## D. TAKE-UP THREAD AND ARM SHAFT MECHANISM

Fig No.	Part. No.	Description	Pcs.	Remarks
D01	H2405D0664	Screw	2	
D02	HD417D8001	Bushing	1	
D03	H2405D1122	Oil wick	1	
D04	H32422C108	Thread Take-up guide bracket pin	1	
D05	HF805C8001	Thread Take-up lever	1	
D06	HE034C8001	Thread Take-up slide block	1	
D07	HA110D0672	Screw	2	
D08	HE038C8001	Oil wick	1	
D09	H2405D0662	Thread Take-up crank pin	1	
D10	HFD4058001	Needle bar connecting link	1	
D11	HE707E8001	Needle bar connecting	1	
D12	HE018D8001	Screw	1	
D13	HD415D8001	Crank guide	1	
D14	HA100C2190	Screw	2	
D15	HD416D8001	Bell crank guide	1	
D16	HE705E8001	Needle bar	1	
D17	HD413D8001	Bushing	1	
D18	HF806E8001	Needle clamp	1	
D19	H3215K0694	Screw	4	
D20		Needle	4	

## E.PNEUMATIC CONTROL UNIT

---

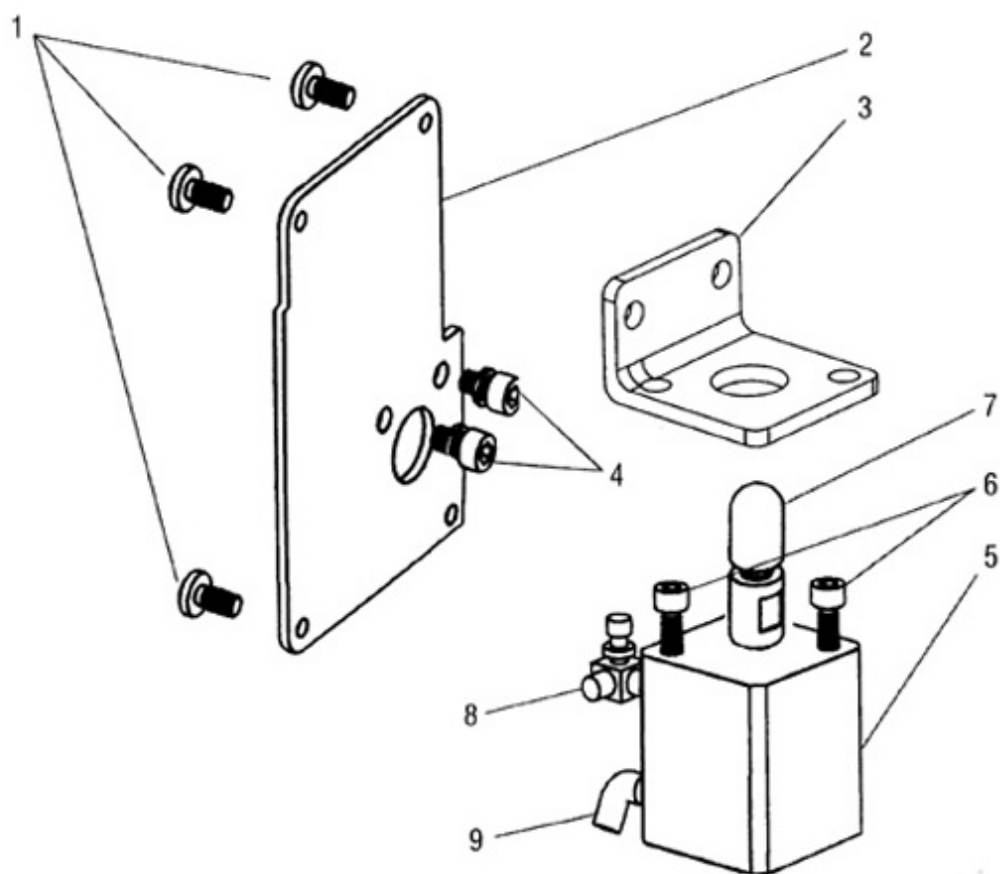

E. PNEUMATIC CONTROL UNIT

Fig No.	Part. No.	Description	Pcs.	Remarks
E01	HA300B2170	Screw	4	
E02	HFE4138001	Cover plate	1	
E03	HFE4148001	Mounting plate	1	
E04	H415050060	Screw	2	
E05	HFE4158001	Cylinder	1	
E06	H415050120	Screw	2	
E07	HFE4168001	Cylinder joint	1	
E08	H0608N8001	valve	1	
E09	H4916G8001	valve	1	

# F.LOWER SHAFT & FEED ROCK SHAFT MECHANISM

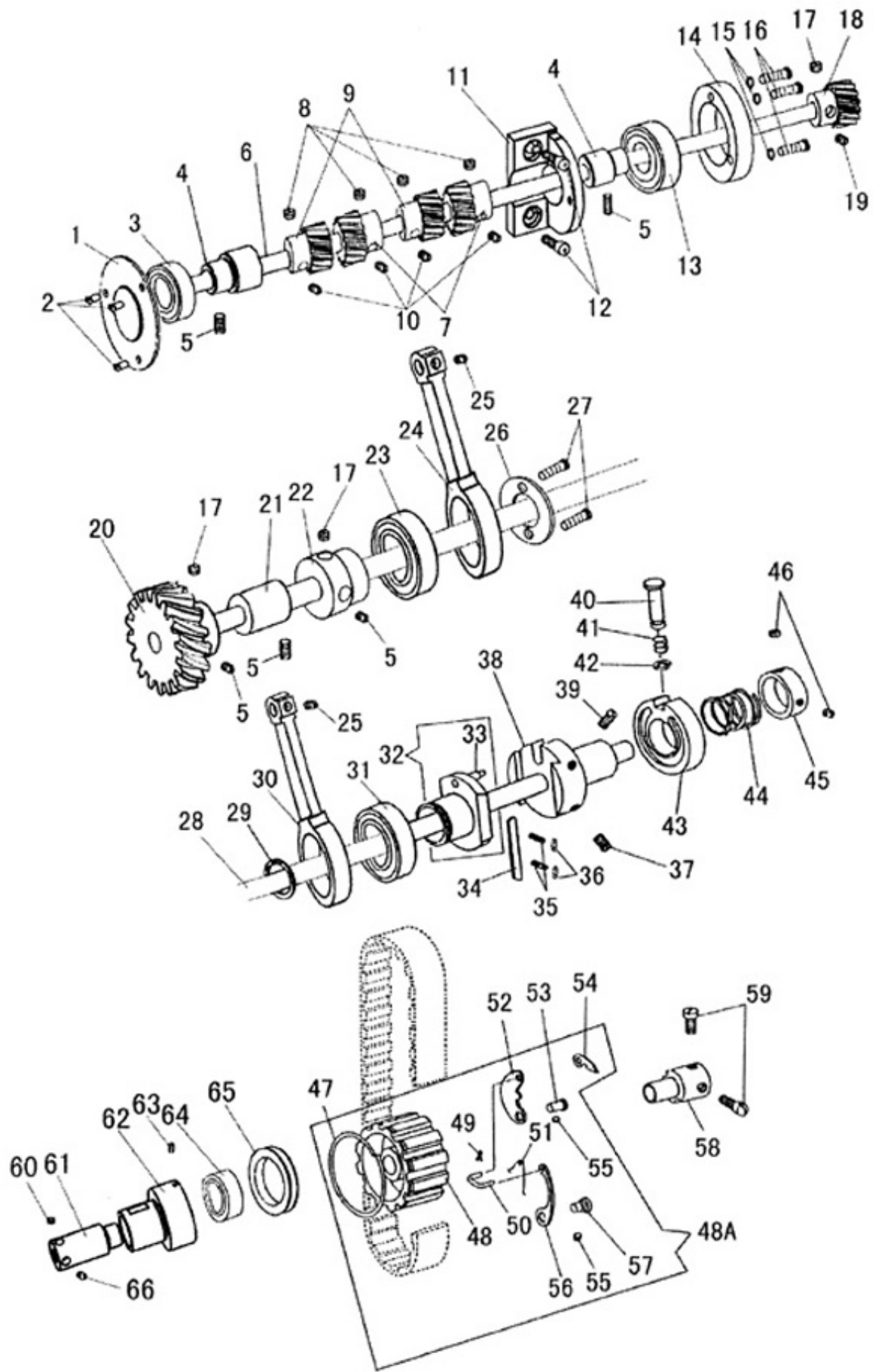

## F.LOWER SHAFT & FEED ROCK SHAFT MECHANISM

Fig. No.	Part No.	Description	Pcs.	Remarks
F01	HF804G8001	Bearing Cover	1	
F02	HA7311C306	Bearing Cover Screw	3	
F03	HF805G8001	Hook Driving Shaft Bearing(Left)	1	
F04	HF806G8001	Hook Driving Shaft Bearing(Left) Bushing	2	
F05	HE023C8001	Hook Driving Shaft Bearing(Left) Bushing Screw	5	
F06	HF807G8001	Hook Driving Shaft	1	
F07	HF808G8001	Hook Driving Gear(Right)	2	
F08	HE107D8001	Hook Driving Gear Position Screw	4	
F09	HF809G8001	Hook Driving Gear(Left)	2	
F10	HE044C8001	Hook Driving Gear Set Screw	4	SM1/4(28)×4.5
F11	HF810G8001	Hook Driving Shaft Bearing(Right) Bracket	1	
F12	H415050100	Hook Driving Shaft Bearing(Right) Bracket Screw	2	
F13	HE016C8001	Hook Driving Shaft Bearing(Right)	1	
F14	HF811G8001	Hook Driving Shaft Bearing(Right) Housing	1	
F15	H4722E8001	Hook Driving Shaft Bearing(Right) Housing Washer	3	4.5×10×0.8
F16	H415040140	Hook Driving Shaft Bearing(Right) Housing Screw	3	
F17	HE017G8001	Hook Driving Shaft Pinion Position Screw	3	
F18	HF812G8001	Hook Driving Shaft Pinion	1	
F19	HE012J8001	Hook Driving Shaft Pinion Set Screw	1	
F20	HF814G8001	Belt Pulley(Lower) Shaft Gear	1	
F21	HF815G8001	Belt Pulley(Lower) Shaft Bushing(Left)	1	
F22	HF816G8001	Feed Lifting Eccentric	1	
F23	HD510C8001	Feed Lifting Eccentric Bearing	1	
F24	HF818G8001	Feed Lifting Eccentric Connection	1	
F25	HA100B2110	Feed Lifting Eccentric Connection Set Screw	2	SM11/64(40)×5.5
F26	HF817G8001	Belt Pulley(Lower) Shaft Bearing Retainer	1	
F27	HE106F8001	Belt Pulley(Lower) Shaft Bearing Retainer Screw	2	SM1/8×44×6
F28	HF819G8001	Belt Pulley(Lower) Shaft	1	
F29	H007013050	Retainer	1	
F30	HF820G8001	Feed Driving Eccentric Connection	1	
F31	HE049C8001	Belt Pulley(Lower) Shaft Bearing	1	
F32	HE042G8001	Feed Driving Eccentric	1	
F33	HE043G8001	Feed Driving Eccentric Pin	1	
F34	HE044G8001	Feed Driving Flange Friction Plate	1	
F35	HE045G8001	Feed Driving Flange Friction Plate Screw	2	SM1/8(44)×7.5
F36	H7258B8001	Feed Driving Flange Friction Plate Nut	2	SM1/8(44)
F37	HE040G8001	Feed Driving Flange Set Screw	1	SM1/4"(32)×11
F38	HE039G8001	Feed Driving Flange	1	
F39	HE041G8001	Feed Driving Flange Position Screw	1	SM1/4"(32)×12
F40	HE051G8001	Feed Regulating Stud	1	
F41	H4107D0672	Feed Regulating Stud Spring	1	
F42	H007013050	Feed Regulating Stud Retaining Spring	1	
F43	HE047G8001	Feed Driving Eccentric Adjusting Disc	1	

## F.LOWER SHAFT & FEED ROCK SHAFT MECHANISM

Fig. No.	Part No.	Description	Pcs.	Remarks
F44	HE048G8001	Feed Driving Eccentric Adjusting Disc Spring	1	
F45	HE049G8001	Feed Driving Eccentric Adjusting Disc Spring Collar	1	
F46	HE023C8001	Feed Driving Eccentric Adjusting Disc Spring Collar Screw	2	SM1/4(32)×5.5
F47	H3205C0661	Pulley Spring Flange	1	
F48	HE019G8001	Safety Clutch Pulley	1	
F49	H601012100	Safety Clutch Throw In Latch Pin	1	
F50	HE027G8001	Safety Clutch Ratchet Connecting Link	1	
F51	HE026G8001	Safety Clutch Throw In Latch Spring	1	
F52	H4719D8001	Safety Clutch Locking Lever	1	
F53	HE029G8001	Hinge Stud	1	
F54	HE031G8001	Safety Clutch Ratchet	1	
F55	HE028E8001	Screw	2	SM7/32(32)×7
F56	HE023G8001	Safety Clutch Locking Lever Spring	1	
F57	HE024G8001	Hinge Pin	1	
F58	HE021G8001	Safety Clutch Collar	1	
F59	HE022G8001	Screw	2	SM1/4(32)×10.5
F60	HE017G8001	Position Screw	1	SM1/4"(32)×5.5
F61	HF840G8001	Belt Pulley(Lower) Shaft Bushing(Right)	1	
F62	HF839G8001	Hook Driving Shaft Bearing(Lower) Bracket	1	
F63	HE013G8001	Ball Bearing Retaning Ring Screw	3	SM0.1339"(3.4)(36)×5
F64	HE016C8001	Ball Bearing	1	
F65	HE018G8001	Ball Bearing Retaning Ring	1	
F66	HE023C8001	Screw	3	SM1/4"(32)×5.5

# G.FEED ROCK SHAFT & THROAT PLATE MECHANISM

---

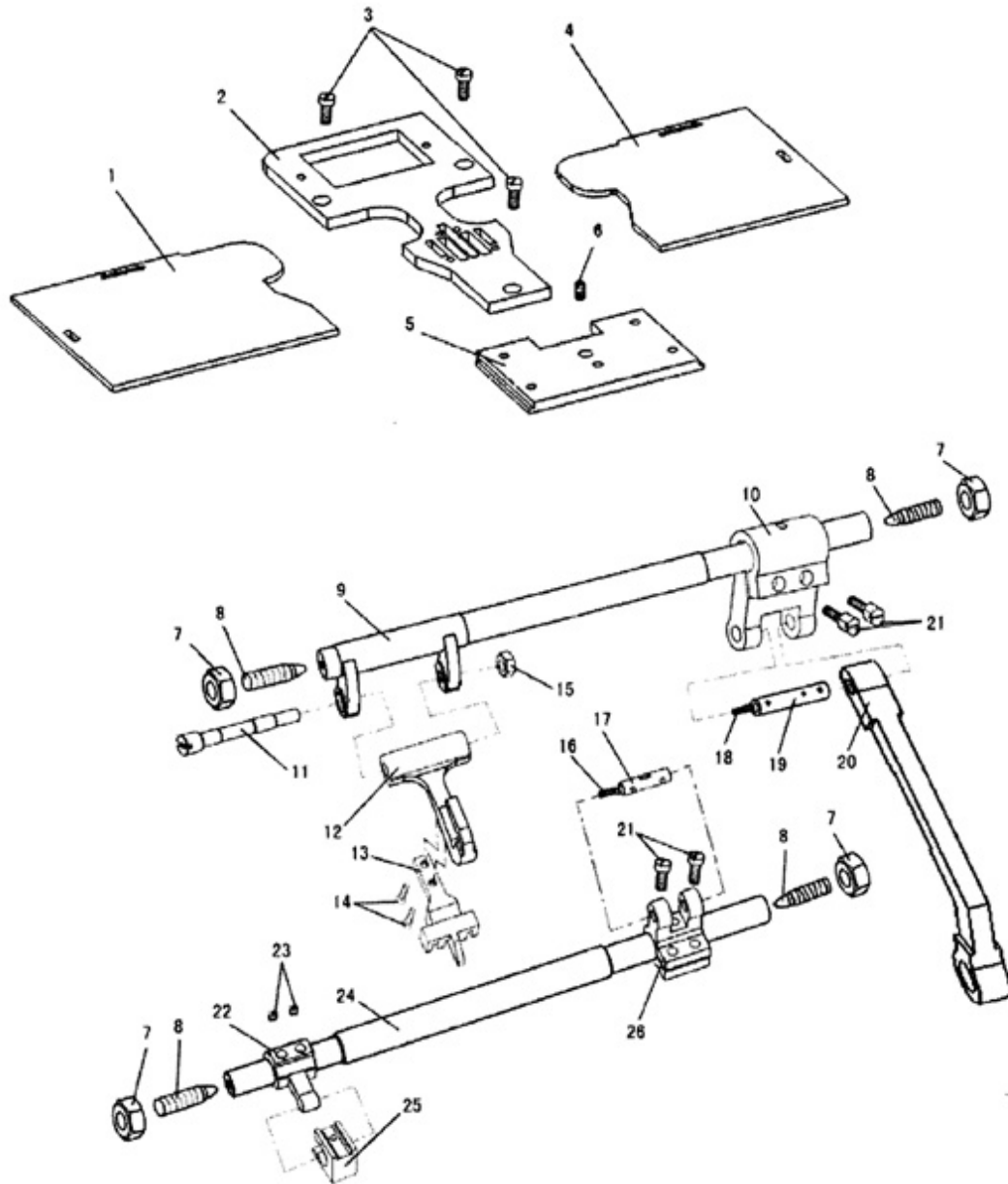

## G.FEED ROCK SHAFT & THROAT PLATE MECHANISM

Fig. No.	Part No.	Description	Pcs.	Remarks
G01	HF805I8001	Slide Plate(Left)	1	
G02	HF804I8001	Throat Plate	1	
G03	HE005H8001	Throat Plate Screw	3	
G04	HF806I8001	Slide Plate(Right)	1	
G05	HF807I8001	Attachment Slide Plate	1	
G06	H428040040	Attachment Slide Plate Screw	1	
G07	HH536C8001	Feed Driving Rock Shaft Center Lock Nut	4	
G08	HF822G8001	Feed Driving Rock Shaft Center	4	SM3/8"(28)
G09	HF821G8001	Feed Driving Rock Shaft	1	
G10	HF823G8001	Feed Driving Rock Shaft Crank	1	
G11	HE026H8001	Feed Bar Hinge Screw	1	
G12	HF831G8001	Feed Bar	1	
G13	HF832G8001	Feed Dog	1	
G14	H32211G205	Feed Dog Screw	2	SM1/8" (40) ×7
G15	HE027H8001	Feed Bar Hinge Screw Nut	1	
G16	HF829G8001	Feed Lifting Connection Connecting Pin Oil Wick	1	
G17	HF826G8001	Feed Lifting Connection Connecting Pin	1	
G18	HF825G8001	Feed Driving Connection Connecting Pin Oil Wick	1	
G19	HF824G8001	Feed Driving Connection Connecting Pin	1	
G20	HF830G8001	Feed Driving Rock Shaft Crank Connection	1	
G21	HA304G0656	Feed Driving Rock Shaft Crank Pinch Screw	4	
G22	HF834G8001	Feed Lifting Rock Shaft Slide Block Crank	1	
G23	H4104C0652	Feed Lifting Rock Shaft Slide Block Crank Set Screw	2	
G24	HF828G8001	Feed Lifting Rock Shaft	1	
G25	HF833G8001	Feed Lifting Cam Fork	1	
G26	HF827G8001	Feed Lifting Rock Shaft Crank	1	



# I.HOOK SADDLE MECHANISM

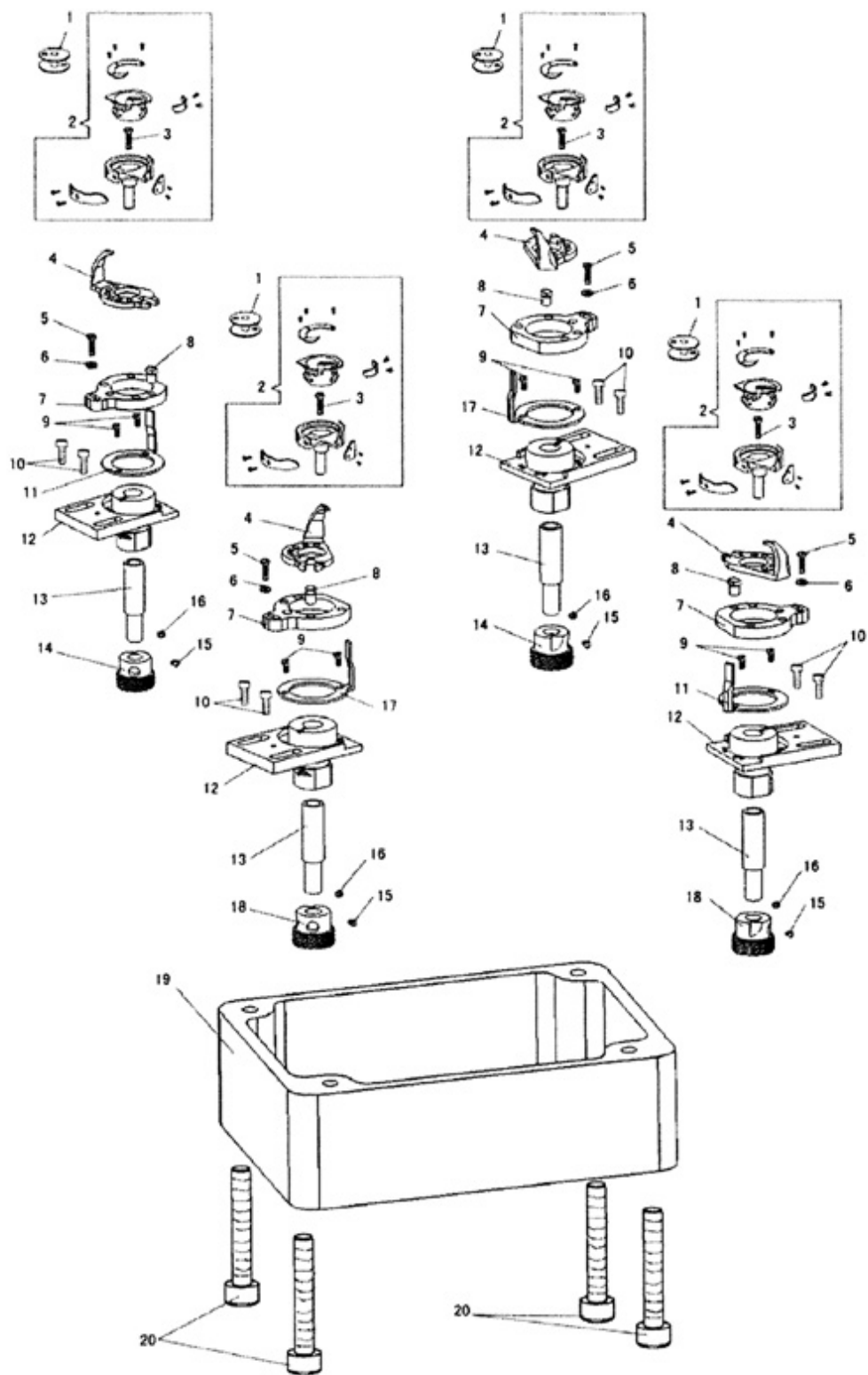

## I.HOOK SADDLE MECHANISM

Fig. No.	Part No.	Description	Pcs.	Remarks
I01	H2400I2020	Bobbin	4	
I02	HF822I7101	Hook And Bobbin Case Complete	4	
I03	H4100D2180	Connecting Screw	4	
I04	H4100D2120	Bobbin Case Opener	4	
I05	H415030120	Bobbin Case Opener Base Screw	4	
I06	H005004030	Bobbin Case Opener Base Washer	4	
I07	HF812I8001	Bobbin Case Opener Base	4	
I08	HF814I8001	Slide Block Pin	4	
I09	HF811I8001	Needle Guard Screw	8	
I10	H415050100	Hook Saddle Screw	8	
I11	HF818I8001	Needle Guard(Right)	2	
I12	HF809I8001	Hook Saddle	4	
I13	HF815I8001	Rotating Hook Shaft	4	
I14	HF816I8001	Hook Shaft Gear(Left)	2	
I15	HE107D8001	Hook Shaft Gear Position Screw	4	
I16	HE044C8001	Hook Shaft Gear Set Screw	4	SM1/4"(28)×4.5
I17	HF810I8001	Needle Guard(Left)	2	
I18	HF819I8001	Hook Shaft Gear(Right)	2	
I19	HF820I8001	Oil Reservoir	1	
I20	H415040250	Oil Reservoir Screw	4	

# J.ROLLER MECHANISM

---

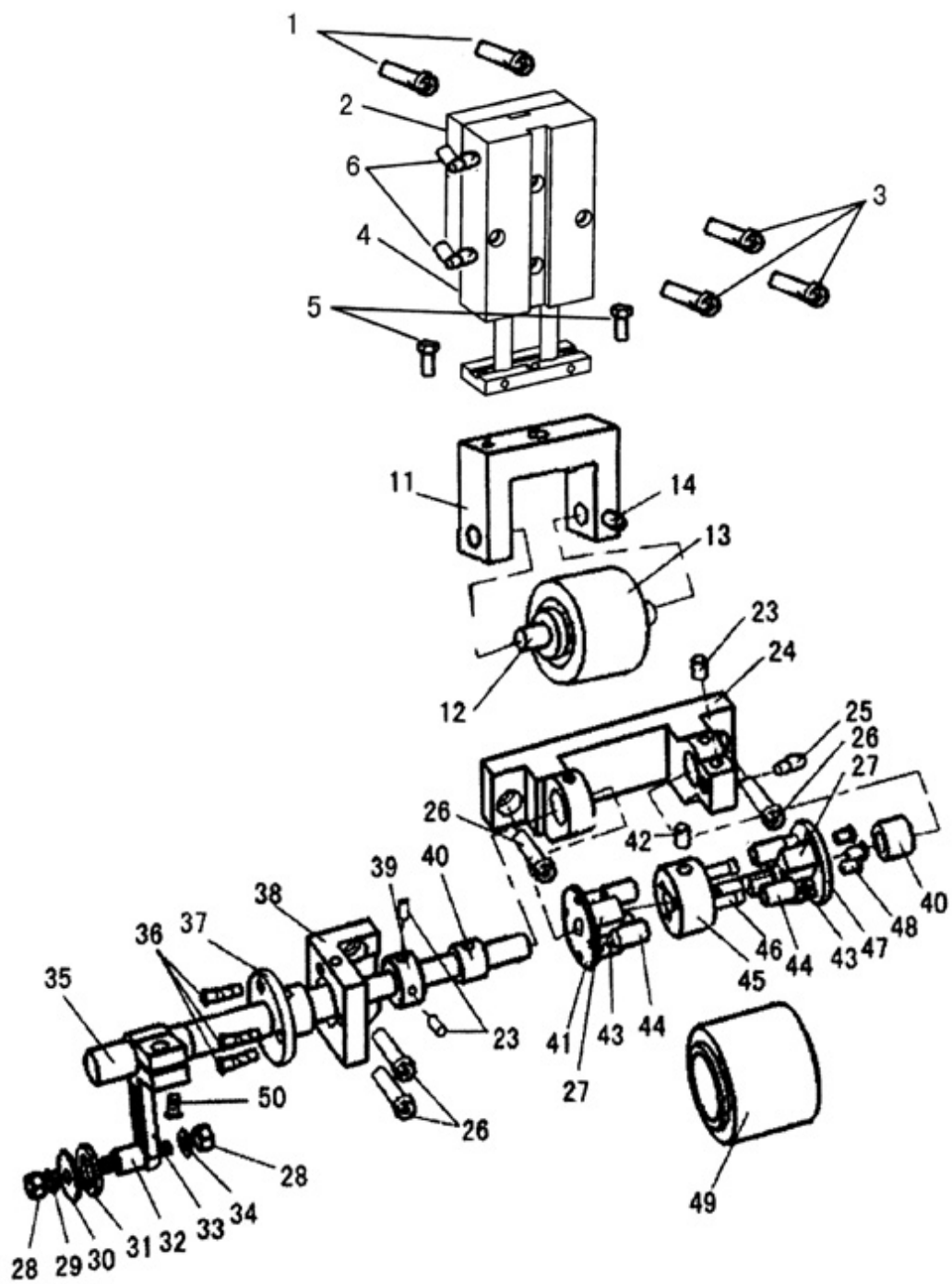

## J. ROLLER MECHANISM

Fig No.	Part. No.	Description	Pcs.	Remarks
J01	H415050120	Screw	2	
J02	HFH4088001	Mounting plate	1	
J03	H415030200	Screw	3	
J04	HF15413021	Cylinder	1	
J05	H415040120	Screw	2	
J06	H4916G8001	valve	2	
J11	HFH4098001	Puller (upper) frame	1	
J12	HE22B88001	Roller (upper) shaft	1	
J13	HE22B97101	Roller (upper) assly	1	
J14	H431050060	Screw	3	
J23	HA100B2110	Puller shaft collar set screw	3	
J24	HF804H8001	Puller (lower) bracket	1	
J25	HF806H8001	Puller (lower) bracket position screw	1	
J26	H415050100	Puller (lower) bracket screw	4	
J27	HF811H8001	Star ferry	2	
J28	H003002050	Bearing inner collar clamp screw nut	2	
J29	H005008050	Spring washer	1	
J30	HF851H8001	Washer	1	
J31	HF850H8001	Washer	1	
J32	HF849H8001	Screw	1	
J33	HF848H8001	Puller shaft arm	1	
J34	H005004050	Small washer	1	
J35	HF820H8001	Puller shaft	1	
J36	H415040080	Set screw	3	
J37	HF824H8001	Bearing	1	
J38	HF823H8001	Puller shaft metal bearing bracket	1	
J39	HF821H8001	Puller shaft collar	1	
J40	HF805H8001	Puller shaft metal bearing	2	
J41	HF807H8001	Clutch disk	1	
J42	H429050060	Lower roller bracket set screw	1	
J43	HF813H8001	Spring	12	
J44	HF812H8001	Rolling shaft	6	
J45	HF814H8001	Lower roller bracket	1	
J46	HF815H8001	Lower roller bracket set screw	3	
J47	HF809H8001	Clutch Plate	1	
J48	HF810H8001	Clutch Plate Set Screw	3	
J49	HF817H7101	Roller (lower) Assiy	1	

# K.OIL LUBRICATION MECHANISM

---

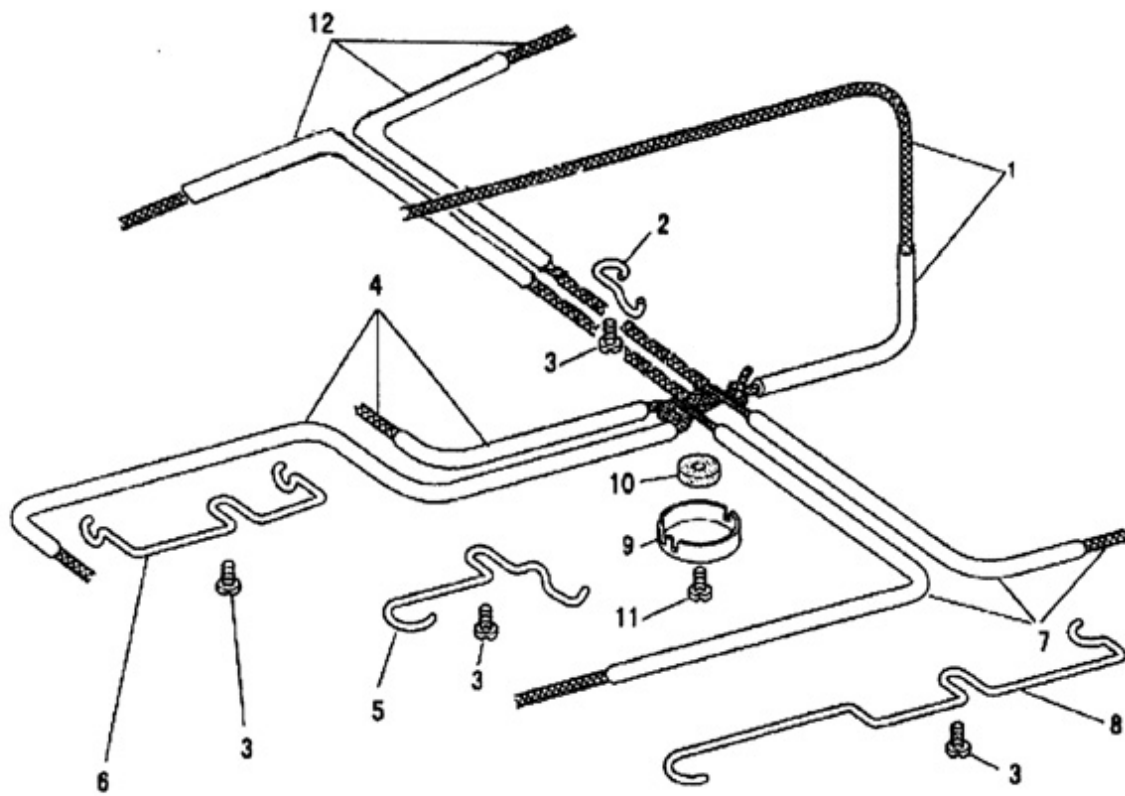

K. OIL LUBRICATION MECHANISM

Fig No.	Part. No.	Description	Pcs.	Remarks
K01	H3209K0066	Oil tube and oil wick	1	
K02	H3200K0170	Retainer	1	
K03	H6623C8001	Screw	4	
K04	HF804K7101	Oil tube and oil wick	1	
K05	H3200K0170	Retainer	1	
K06	H3200K0170	Retainer	1	
K07	HF807K7101	Oil tube and oil wick	1	
K08	H3200K0170	Retainer	1	
K09	HE012L8001	Bed oil tube clamp	1	
K10	HE013L8001	Oil felt	1	
K11	HE014L8001	Screw	1	
K12	HF810K8001	Oil tube and oil wick	1	

# L.ACCESSORIES

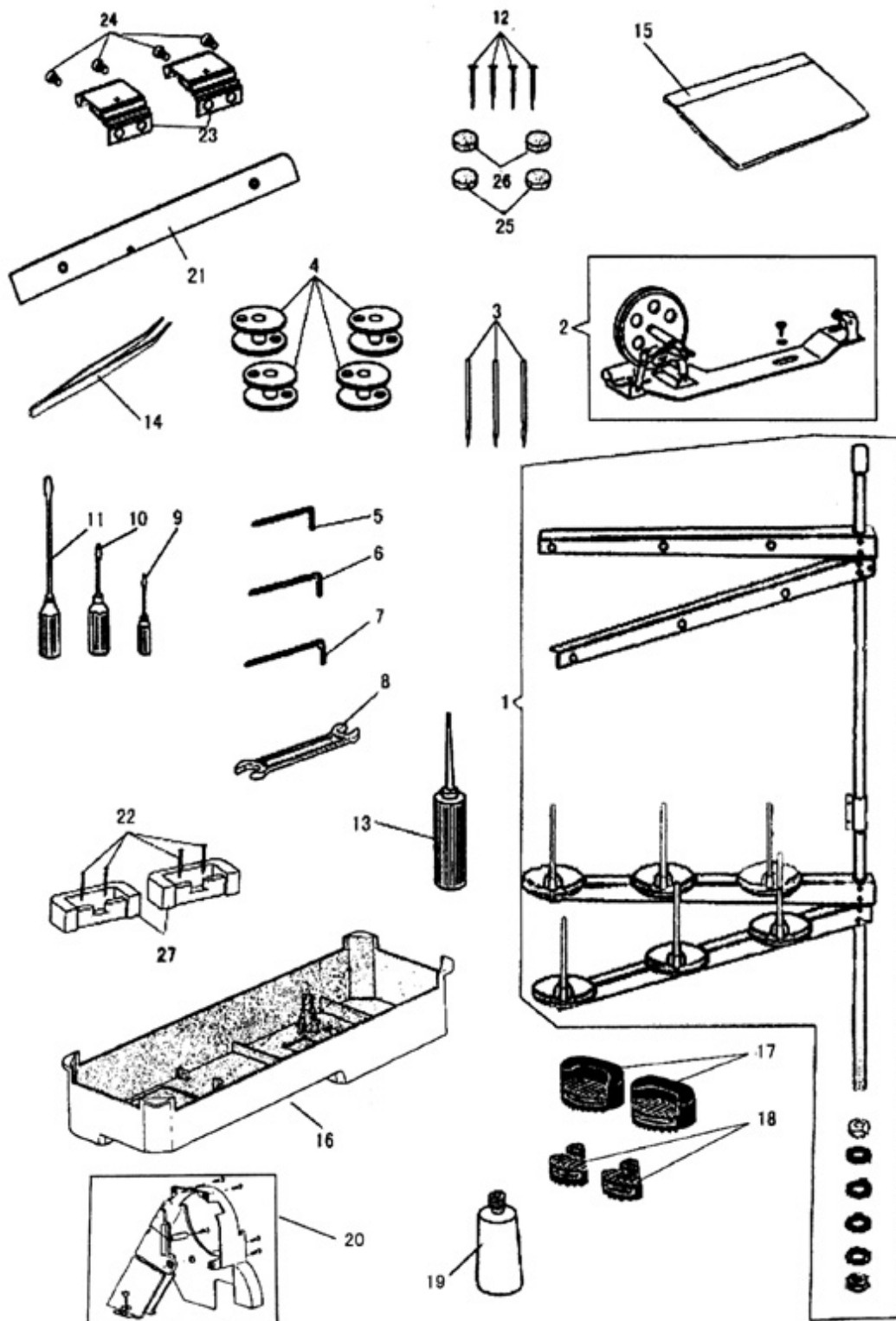

## L. ACCESSORIES

Fig No.	Part. No.	Description	Pcs.	Remarks
L01	HF806L8001	Thread unwinder complete	1	
L02	HA706S0067	Bobbin winder complete	1	
L03	HF807E8001	Needle	4	
L04	H2400I2020	Bobbin	8	
L05	HB00001015	Wrench	1	
L06	HB00001030	Wrench	1	
L07	HB00001025	Wrench	1	
L08	HA300J2220	Double head wrench	1	
L09	HA300J2210	Screw Driver	1	
L10	HA300J2200	Screw Driver	1	
L11	HA300J2070	Screw Driver	1	
L12	H403060080	Screw	4	
L13	HA100J2110	Oil bottle	1	
L14	HE015M8001	Tweezers	1	
L15	HA300J2150	Accessories pack	1	
L16	HF810L7101	Drip pan	1	
L17	H802035190	Machine rest	2	
L18	HE013M8001	Machine rest	2	
L19	HE014M7101	Oil bottle	1	
L20	H802055250	Belt guard complete	1	
L21	HF805L8001	Cover board	1	
L22	HZB1016250	Nail	4	
L23	HF804L8001	Machine hinge connection	2	
L24	HE010M8001	Screw	4	
L25	H200500066	Machine rest	2	
L26	H200400065	Machine rest	2	
L27	HE007M8001	Machine hinge connection cushion	2	



**SHANGHAI HUIGONG NO.3 SEWING MACHINE FACTORY**

**ADD: No.850, ShuLin Road, SongJiang District, Shanghai, P.R. China**

**Zip Code: 201612**

**Overseas Business: TEL: 86-21-64853303 FAX: 86-21-64854304**

**E-mail: [highlead@online.sh.cn](mailto:highlead@online.sh.cn) <http://www.highlead.com.cn>**

The description covered in this manual is subject to change for improvement of the commodity without notice

2019.6. Printed